

# CIAIAC

COMISIÓN DE  
INVESTIGACIÓN  
DE **A**CCIDENTES  
E **I**NCIDENTES DE  
**A**VIACIÓN **C**IVIL

## Report IN-005/2015

Incident involving a Bombardier CRJ1000 (CL-600-2E25) aircraft, registration EC-LPG, operated by Air Nostrum, at the Adolfo Suárez Madrid-Barajas Airport (LEMD) on 1 February 2015



GOBIERNO  
DE ESPAÑA

MINISTERIO  
DE FOMENTO



# Report

## IN-005/2015

---

**Incident involving a Bombardier CRJ1000  
(CL-600-2E25) aircraft, registration EC-LPG,  
operated by Air Nostrum, at the Adolfo Suárez  
Madrid-Barajas Airport (LEMD) on 1 February 2015**



GOBIERNO  
DE ESPAÑA

MINISTERIO  
DE FOMENTO

SUBSECRETARÍA

COMISIÓN DE INVESTIGACIÓN  
DE ACCIDENTES E INCIDENTES  
DE AVIACIÓN CIVIL

Edita: Centro de Publicaciones  
Secretaría General Técnica  
Ministerio de Fomento ©

NIPO: 161-17-050-1

Diseño, maquetación e impresión: Centro de Publicaciones

---

COMISIÓN DE INVESTIGACIÓN DE ACCIDENTES E INCIDENTES DE AVIACIÓN CIVIL

Tel.: +34 91 597 89 63  
Fax: +34 91 463 55 35

E-mail: [ciaiac@fomento.es](mailto:ciaiac@fomento.es)  
<http://www.ciaiac.es>

C/ Fruela, 6  
28011 Madrid (España)

## **Foreword**

This report is a technical document that reflects the point of view of the Civil Aviation Accident and Incident Investigation Commission (CIAIAC) regarding the circumstances of the accident object of the investigation, and its probable causes and consequences.

In accordance with the provisions in Article 5.4.1 of Annex 13 of the International Civil Aviation Convention; and with articles 5.5 of Regulation (UE) n° 996/2010, of the European Parliament and the Council, of 20 October 2010; Article 15 of Law 21/2003 on Air Safety and articles 1., 4. and 21.2 of Regulation 389/1998, this investigation is exclusively of a technical nature, and its objective is the prevention of future civil aviation accidents and incidents by issuing, if necessary, safety recommendations to prevent from their reoccurrence. The investigation is not pointed to establish blame or liability whatsoever, and it's not prejudging the possible decision taken by the judicial authorities. Therefore, and according to above norms and regulations, the investigation was carried out using procedures not necessarily subject to the guarantees and rights usually used for the evidences in a judicial process.

Consequently, any use of this report for purposes other than that of preventing future accidents may lead to erroneous conclusions or interpretations.

This report was originally issued in Spanish. This English translation is provided for information purposes only.



---

## Table of contents

---

|  |     |
|--|-----|
| <b>Abbreviations</b> .....   | vii |
| <b>Synopsis</b> .....  | ix  |
| <b>1. Factual information</b> .....  | 1   |
| 1.1. History of the flight.....  | 1   |
| 1.2. Injuries to persons.....  | 2   |
| 1.3. Damage to aircraft.....   | 2   |
| 1.4. Other damage.....   | 3   |
| 1.5. Personnel information .....   | 4   |
| 1.5.1. Crew information.....   | 4   |
| 1.5.2. Information on the LEPP controller .....  | 4   |
| 1.5.3. Information on the LEMD controller .....  | 4   |
| 1.6. Aircraft information.....   | 5   |
| 1.6.1. General information.....  | 5   |
| 1.6.2. Information on the landing gear.....  | 5   |
| 1.6.3. Information on the flat spots.....  | 8   |
| 1.6.4. Information on carbon brakes.....   | 8   |
| 1.6.5. Maintenance information.....  | 9   |
| 1.7. Meteorological information .....  | 10  |
| 1.8. Aids to navigation.....   | 12  |
| 1.9. Communications .....  | 12  |
| 1.10. Aerodrome information .....  | 12  |
| 1.11. Flight recorders .....   | 13  |
| 1.12. Wreckage and impact information.....   | 14  |
| 1.13. Medical and pathological information.....  | 14  |
| 1.14. Fire .....   | 14  |
| 1.15. Survival aspects .....   | 14  |
| 1.16. Tests and research .....   | 14  |
| 1.17. Organizational and management information.....   | 15  |
| 1.17.1. Information from the manufacturer and operator regarding snow<br>or ice in the gear..... | 15  |
| 1.17.2. Information from the ATC service provider at LEPP, Enaire .....                          | 19  |
| 1.17.3. Information from Pamplona Airport (LEPP) personnel .....                                 | 19  |
| 1.17.4. Information on the Adolfo Suárez- Madrid Barajas Airport (LEMD) .....                    | 24  |
| 1.17.5. Information from the ATC services provider at LEMD, Enaire .....                         | 26  |
| 1.18. Additional information .....   | 27  |
| 1.18.1. Statement from the crew.....   | 27  |
| 1.18.2. Statement from the mechanic involved in deicing .....                                    | 29  |
| 1.18.3. Statement from the local controller at LEPP.....   | 29  |
| 1.18.4. Statement from the RFFS Chief at LEPP .....  | 30  |
| 1.19. Useful or effective investigation techniques .....   | 30  |

- 2. Analysis** ..... 31
  - 2.1. Analysis of the braking system on the aircraft ..... 31
  - 2.2. Analysis of the crew's actions ..... 34
  - 2.3. Analysis of the actions taken by the Pamplona Airport (LEPP) ..... 35
  
- 3. Conclusions** ..... 37
  - 3.1. Findings ..... 37
  - 3.2. Causes/Contributing factors ..... 39
  
- 4. Safety recommendations** ..... 41
  
- 5. Appendices** ..... 43



## **Abbreviations**

|         |  |
|---------|--|
| ACC     | Air Control Center   |
| ADI     | Aerodrome control instrument                                 |
| AENA    | Gestor aeroportuario español- Spanish airport manager        |
| AESA    | Spanish Aviation Safety Agency                               |
| AFM     | Airplane Flight Manual                                       |
| AGL     | Above Ground Level   |
| AIP     | Aeronautical Information Publication                         |
| AIR     | Air control  |
| APP     | Approach/ Approach control procedural                        |
| ASCU    | Anti- skid control unit                                      |
| ASCV    | Antiskid control valve                                       |
| ATC     | Air Traffic Control  |
| ATPL    | Airline Transport Pilot License                              |
| BCV     | Brake control valve  |
| BTMS    | Brake Temperature Monitoring System                          |
| BPMS    | Brake Pressure Monitoring System                             |
| CECOA   | Operations Coordination Center                               |
| CEGRA   | Aena Aeropuertos Network Management Center                   |
| CGA     | Airport Management Center                                    |
| Cm      | Centimeters  |
| COAM    | Movement area operations coordinator                         |
| CVR     | Cabin Voice Recorder   |
| DFDR    | Digital Flight Data Recorder                                 |
| DGAC    | Spain's Civil Aviation General Directorate                   |
| DOW     | Dry Operating Weight   |
| EASA    | European Aviation Safety Agency                              |
| EICAS   | Engine Indication and Crew Alerting System                   |
| FA      | Flight Attendant   |
| FCOM    | Flight Crew Operations Manual                                |
| FDM     | Flight Data Monitoring                                       |
| FOD     | Foreign Object Debris  |
| Ft      | Feet   |
| GLD     | Ground Lift Dumping  |
| GMC     | Ground movement control                                      |
| GMS     | Ground movement surveillance                                 |
| GND     | Ground   |
| HOT     | Holdover Time  |
| IATA    | International Aviation Transport Agency                      |
| IBD     | Inboard  |
| IR      | Instrumental Rating  |
| JAR-FCL | Joint Aviation Regulations – Flight Crew Licenses            |
| Kg      | Kilograms  |
| Km      | Kilometers   |
| Kt      | Knots  |
| LEMD    | OACI code of Adolfo Suárez Madrid-Barajas Airport            |
| LEPP    | OACI code of Pamplona Airport                                |
| LH      | Left Hand  |
| m       | Meters   |
| METAR   | Meteorological Terminal Air Report                           |
| Mm      | Milimeters   |
| MOTNE   | Meteorological Operational Telecommunications Network Europe |
| MTOW    | Maximum Takeoff Weight                                       |
| N/A     | Not applicable   |
| NM      | Nautical Miles   |
| OBD     | Outboard   |

|            |  |
|------------|--|
| OFF        | Operational Flight Plan                          |
| OMA        | Airport Weather Office                           |
| OVHT       | Overheat   |
| PF         | Pilot Flying                                     |
| PNA        | IATA Code of Pamplona Airport                    |
| Psi        | Pounds per square inch                           |
| QAR        | Quick Access Recorder                            |
| QNH        | Atmospheric Pressure (Q) at Nautical Height      |
| RAD        | Radar control                                    |
| RFFS       | Rescue and Firefighting Service                  |
| RH         | Right Hand                                       |
| SPECI-     | Special aviation weather report                  |
| t          | Tons   |
| TAF /TAFOR | Terminal Arodrome Forecast                       |
| TCCA       | Transport Canada Civil Aviation                  |
| TO         | Takeoff  |
| TOAM       | Movement Area Operations Technician (Marshaller) |
| TWR        | Tower control                                    |
| TWY        | Taxiway  |
| UTC        | Coordinated Universal Time                       |
| WARN       | Warning  |
| WOW        | Weight On Wheels                                 |

## Synopsis

|                            |  |
|----------------------------|--|
| Owner and Operator:        | Air Nostrum  |
| Aircraft:                  | Bombardier CRJ1000 (CL-600-2E25 <sup>1</sup> ), EC-LPG                     |
| Date and time of incident: | Sunday, 1 February 2015 at 06:51 <sup>2</sup>                              |
| Site of incident:          | Adolfo Suárez Madrid Barajas Airport (LEMD)                                |
| Persons onboard:           | 2 flight crew, 2 flight attendants (FA)<br>and 63 passengers. None injured |
| Type of flight:            | Commercial air transport - Scheduled - Domestic -<br>Passenger             |
| Date of approval:          | 28th September 2016  |

### Summary of the incident

The aircraft took off at 06:13 from the Pamplona Airport (LEPP) after spending the night there. It has been snowing all night and it was still snowing intermittently. The snow plows had been working to clear the runway. The aircraft was deiced and it taxied on the apron, which had standing slush. The aircraft later took off normally from the runway in use, 33, which also had slush on it. The flight was uneventful but upon landing at the destination airport, the crew felt vibrations coming from the main gear, which they identified as a blowout. They reported this to ATC and requested a nearby parking stand. Once there, the crew confirmed that the tire on the outboard left wheel (no. 1) had burst, there was a flat spot<sup>3</sup> on the outboard right tire (no. 4) and there was white ice on the main gear wheels. Debris from a tire and from the gear door, as well as several pieces of white ice, were found on the runway where the aircraft had touched down. The occupants were not injured and they were disembarked normally.

The investigation considered the aspects related to the operation of the aircraft, the procedures put in place by both the manufacturer and the operator for operating in contaminated runway conditions, and the airport's procedures to clean runways and measure parameters such as contaminant depth and the coefficient of friction.

It was considered that the main cause of the incident is that part of the slush encountered during the aircraft's taxiing and subsequent takeoff run could have entered the landing

---

<sup>1</sup> Designation on the Type Certificate

<sup>2</sup> All times in this report are in UTC unless otherwise specified. To obtain local time, add one hour to UTC time.

<sup>3</sup> See definition in Section 1.6.3.

gear bays and adhered to the components there. When the gear was retracted, tires number 1 and 4 were in the lowest position and were thus more exposed to the low temperatures present during the flight. As a result, any slush present could have fallen due to gravity to the brake assembly and then frozen.

The following contributed to the incident:

- The improper cleaning of the runways at the Pamplona Airport which resulted in the presence of slush on the apron and cordons of slush on both the taxiway and the runway.
- The improper operation taken by the crew for taking off from a contaminated runway, namely not heating the brakes and not delaying the retraction of the landing gear to allow the contaminant to fall away. The crew also did not make a positive landing to ensure that any remaining frozen contaminant was dislodged.

## 1. FACTUAL INFORMATION

### 1.1. History of the flight

On 31 January 2015, the aircraft landed at the Pamplona Airport (LEPP) on its last flight of the day. When it arrived at the parking stand, there was a considerable amount of snow built up on the gear (see photograph 1 below). According to the maintenance technician, the snow was cleaned off manually. Some ice remained in areas that were hard to reach, but it melted over the course of the night, during which it continued to snow.



**Photograph 1. Condition of the gear the night before the incident**

The next day it was still snowing, though intermittently. According to the crew's statement, the contaminant on the surface was snow mixed with ice pellets, though they did not see any snow build-up on the aircraft. The snow plows had been working to clear the runway, but not the apron. The aircraft was deiced. The crew reported they had received information on braking efficiency<sup>4</sup> for each third of the runway (the crew recalled the values were Medium-Medium-Medium to Poor) in the direction of the 33 threshold, in the direction of the runway in use. The only weather information they had was a TAFOR because when they arrived at the airport in the morning it was still closed. The tower controller at LEPP was asked to clear the runway and to measure the braking efficiency again. The ground could be seen through the built-up slush, though vehicles

---

<sup>4</sup> Parameter directly related to the coefficient of friction.

left tracks in it when they passed over it. The taxi distance from the apron to the runway was not long, and once the aircraft was deiced, the aircraft started taxiing to the threshold, which took about five minutes. They did not hurry so they could have enough time to give the safety briefing<sup>5</sup> to the passengers. They took off normally at 06:13 from runway 33 at the Pamplona Airport (LEPP).

The flight was uneventful but upon landing at the destination airport, the crew felt vibrations coming from the main gear, which they initially identified as a blowout. According to the information in the QAR<sup>6</sup>, the aircraft touched down at 06:51:30 (the gear "down and locked" sensors were activated). The crew asked the tower controller for a visual check of the condition of the gear. The crew of an aircraft from another operator informed them that something was wrong with the left gear door. After this, the TOAM<sup>7</sup> (marshaller) confirmed that the number 1 tire had burst. The crew notified the operator's maintenance personnel and asked the control tower for a nearby parking stand. Once there, it was confirmed that the outboard left tire (number 1) had burst and had a flat spot before the blowout. The outboard right tire (number 4) also had a flat spot. There were chunks of white ice stuck to the landing gear legs, and debris from a tire and from the gear door, as well as several pieces of white ice, were found on the runway where the aircraft had touched down.

### 1.2. Injuries to persons

| Injuries | Crew | Passengers | Total in the aircraft | Others |
|----------|------|------------|-----------------------|--------|
| Fatal    |      |            |                       |        |
| Serious  |      |            |                       |        |
| Minor    |      |            |                       | N/A    |
| None     | 2+2  | 63         |                       | N/A    |
| TOTAL    | 4    | 63         | 67                    |        |

### 1.3. Damage to aircraft

The number 1 tire showed signs of a flat spot, as did the number 4 tire, though it did not burst. The blowout of the number 1 tire damaged the inboard left flap, slightly bending part of the trailing edge upward. The gear door broke off its fittings, and one flap fairing was also damaged.

---

<sup>5</sup> Instructions given to the passengers by the cabin crew.

<sup>6</sup> QAR- Quick Access Recorder

<sup>7</sup> TOAM- Movement Area Operations Technician (marshaller)



**Photograph 2. Conditions of tires 1 and 4**



**Photograph 3. Blocks of ice still adhering to the brake assemblies**

#### **1.4. Other damage**

There was no additional damage beyond that detected on the aircraft.

## 1.5. Personnel information

### 1.5.1. Crew information

The captain, a 53-year old Spanish national, had a JAR-FCL airline transport pilot license (ATPL(A)) with CRJ100 and instrument ratings, both valid and in force until 31 August 2015. He also had class 1 and 2 medical certificates that were valid and in force until 4 October 2015. On the date of the incident he had a total of 12916:28 flight hours, of which 8263:28 had been on the type (CL-65).

The captain took the winter operations course, as scheduled, in July of 2014.

The first officer, a 35-year old Spanish national, had a JAR-FCL airline transport pilot license (ATPL(A)) with CRJ100 and instrument ratings, both valid and in force until 31 May 2015. He also had a class-1 medical certificate that was valid and in force until 8 November 2015, and a class-2 certificate that was valid and in force until 8 November 2019. He had a total of 6636:58 flight hours, of which 5253:53 had been on the type (CL-65).

The first officer took the winter operations course, as scheduled, in August of 2014.

### 1.5.2. Information on the LEPP controller

The local takeoff and landing controller at LEPP was a 38-year old Spanish national. He had a valid EU air controller license with the LEPP unit endorsement and the following ratings and rating endorsements: ADI<sup>8</sup>/AIR<sup>9</sup>-RAD<sup>10</sup>, ADI/GMC<sup>11</sup> and ADI/TWR<sup>12</sup>/RAD and APP<sup>13</sup> (until 20 January 2016). He had been stationed at LEPP since 2010. He also had a class-3 medical certificate that was valid and in force until 12 October 2016.

### 1.5.3. Information on the LEMD controller

The local landing controller at LEMD was a 44-year old Spanish national. He had a valid EU air controller license with the LEMD unit endorsement and the following ratings and rating endorsements: ADI/AIR-RAD, ADI/GMC-GMS<sup>14</sup> and ADI/TWR/GMS/RAD (until 25

---

<sup>8</sup> Aerodrome control instrument

<sup>9</sup> Air control

<sup>10</sup> Radar control

<sup>11</sup> Ground movement control

<sup>12</sup> Tower control

<sup>13</sup> Approach control procedural

<sup>14</sup> Ground movement surveillance



August 2015). He had been stationed at LEMD since 2008. He had an On-the-Job Training Instructor rating that was valid and in force until 10 April 2016. He also had a class-3 medical certificate that was valid and in force until 23 July 2015.

## 1.6. Aircraft information

### 1.6.1. General information

The aircraft, a Bombardier CRJ1000 (CL-6002E25<sup>15</sup>), registration EC-LPG and serial number 19021, was manufactured in 2011. This aircraft is equipped with two General electric CF34-8C5 engines and has a maximum takeoff weight (MTOW<sup>16</sup>) of 40995 kg and a dry operating weight (DOW) of 22712 kg.

The aircraft had a Registration Certificate, a Certificate of Airworthiness, an Aircraft Station License, a Noise Certificate and an Insurance Certificate, all of them valid and in force.



Photograph 4. The incident aircraft<sup>17</sup>

### 1.6.2. Information on the landing gear

The main landing gear consists of two gear assemblies mounted underneath the wings. The gear folds inward into two bays or compartments in each wing and the fuselage for the wheel. There is a door attached to each gear assembly that covers the gear when it is retracted. In this case this door does not cover the main wheels.

---

<sup>15</sup> Type Certificate designation

<sup>16</sup> MTOW Maximun Take Off Weight- Peso máximo al aterrizaje

<sup>17</sup> Image taken from <http://www.planespotters.net>

Each gear structure includes a strut and two identical tires that support the aircraft's weight. The wheels are numbered from left right, with the number 1 wheel being the outboard left wheel and the number 4 being the outboard right wheel. When the gear is retracted, wheels 1 and 4 are on the outside of the fairing and are not "protected" by the landing gear bay door.

There are sensors located on the outside of the strut that provide information on when the aircraft is located on the ground by means of the weight on wheels (WOW) switch. There is another signal that provides an indication of wheel rotation. In normal conditions, when the aircraft lands, no pressure is applied to the brake assemblies even if the pilot steps on the pedals. It is not until the WOW sensor is activated and the wheel starts to rotate (wheel rotation signal) that the braking system is activated and can start to function.

The brake system (see Figure 1) controls the hydraulic pressure that is routed to the brakes through two BCV (brake control valves). The inboard BCV receives pressure from the number 2 hydraulic system, and the outboard BCV from the number 3 hydraulic system. The OBD BCV controls the brakes on wheels 1 and 4, while the IBD BCV brakes wheels 2 and 3 (see Photograph 5).

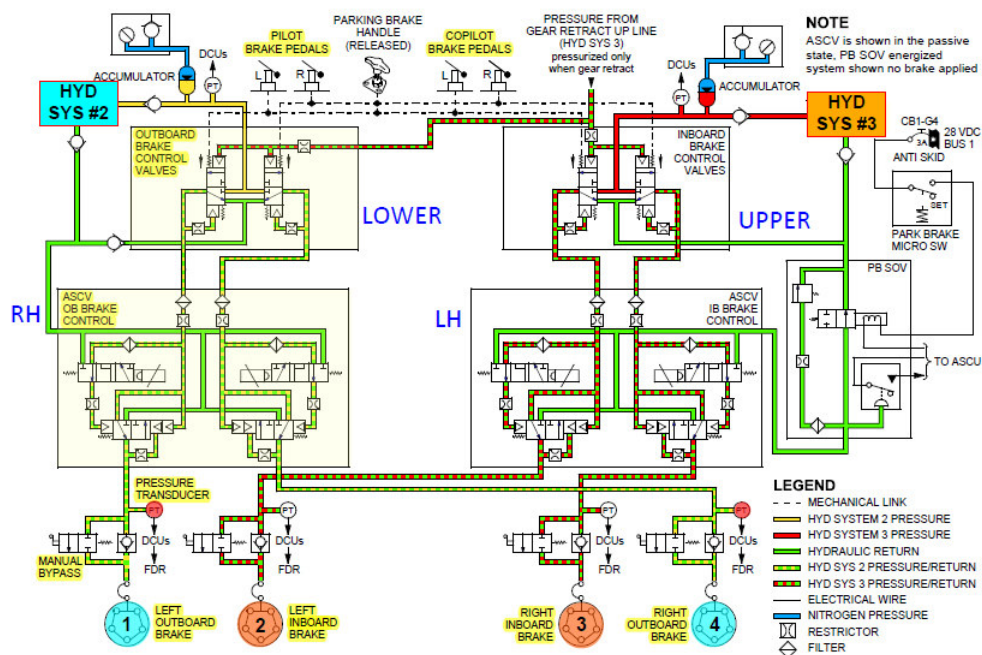

Figure 1. Brake system schematic



**Photograph 5. Brake control valves (BCVs)**

The anti-skid system<sup>18</sup> controls the hydraulic pressure that is routed to the brakes on the four main wheels to provide skid control. This system is controlled through the anti-skid control unit (ASCU), which is divided into inboard and outboard channels. The anti-skid control valves (ASCV) are located in the main landing gear bay and are controlled by the ASCU.

The hydraulic pressure for the brakes on the number 1 and 4 wheels, which were damaged during the incident, is supplied from the number 2 hydraulic system, through the Outboard Brake Control Valve (OBD BCV) and the Outboard Anti-Skid Control Valve (OBD ASCV). The OBD BCV measures the pressure and passes it through to the ASCV based on the pressure being applied to the brake pedals in the cockpit. This pressure will be available for braking unless prevented by the ASCU (if the wheels are not turning, for example).

The Brake Temperature Monitoring System (BTMS) constantly monitors the temperature of each main wheel braking assembly. The system consists of four temperature sensors (one per braking unit), the ASCU unit and a switch to reset the system when the brake overheating condition clears (BTMS OVHT WARN RESET). The ASCU receives the brake temperature signals and relays them to the EICAS, where they can be displayed. Any time the main gear is down or when a brake overheat condition is present, temperature information for the four brakes will be displayed on the EICAS using the color code shown (see Figure below):

<sup>18</sup> System that keeps the wheels from locking during braking by releasing brake pressure based on a limiting speed.

|       |                            |                  |
|-------|----------------------------|------------------|
| Green | 6 or less                  | (237°C)          |
| White | 7 to 14                    | (238°C to 537°C) |
| Red   | Overheat or higher than 14 | (over 538°C)     |

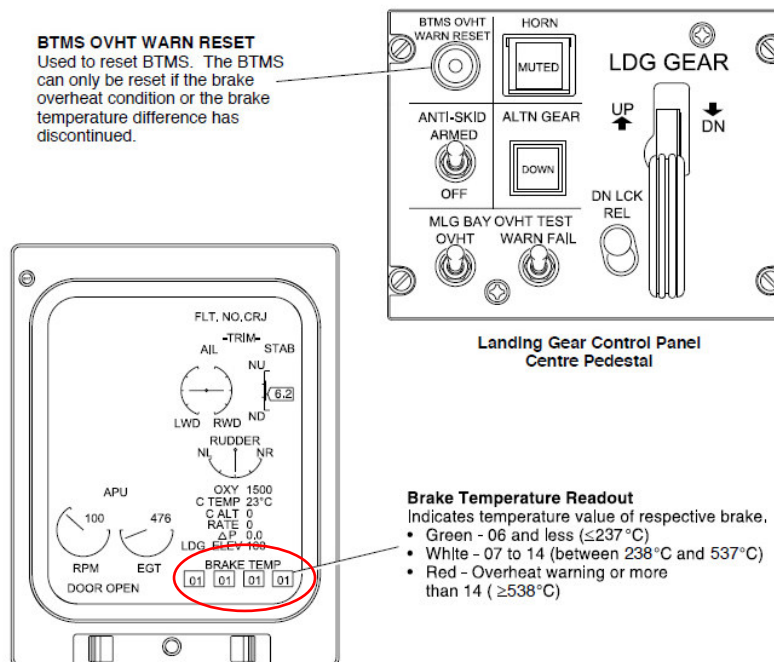

Figure 2. Location of brake temperature readout

The Brake Pressure Monitoring System (BPMS) monitors the brake pressure on the inboard and outboard main gear brake systems. Pressure to the inboard system is supplied by the number 3 hydraulic system, and to the outboard by the number 2 hydraulic system. The readouts for these pressures are displayed on the EICAS and there are alert messages to warn if the pressure drops below a certain level.

### 1.6.3. Information on the flat spots

A flat spot is a flat section on the rubber of the tire produced by friction in a given area of the tire (see Photograph 2). This friction occurs when the brakes lock, and the wheel is prevented from rotating while the aircraft continues to move forward. This phenomenon can occur at the instant that the airplane touches down, when the wheel is stopped (leading to a small flat spot), or when the brakes are locked (resulting from a malfunction of the anti-skid system or when the brake assembly seizes).

### 1.6.4. Information on carbon brakes

Unlike other CRJ aircraft flown by the operator (such as the CRJ900), the incident aircraft, a Bombardier CRJ1000, features carbon brakes with three pairs of discs (rotor-

stator) instead of steel brakes with five pairs of discs. The operating procedures for carbon brakes are different from those for steel brakes.

Carbon brakes have a number of operational advantages over steel such as lighter weight, longer life, and greater energy absorption capability. Carbon brakes are more efficient at high temperatures, though at low temperatures they are as effective as steel brakes. Carbon brake wear, however, is highly dependent on brake temperature and carbon brakes wear rapidly when cold (i.e., during the initial part of taxi out). In order to maximize the life of carbon brakes, pilots have to avoid dragging the brakes while taxiing. In order to maintain taxi speed, the brakes should be used less frequently but more firmly, allowing the taxi speed to regulate so as to reach the required speed. If taxi speed is too high and conditions (environmental, surface, passenger comfort, etc) permit, reduce speed by using one long, moderately firm brake application. These recommendations are general guidelines only, safety and passenger comfort should be the primary considerations.

Several recommendations on how to use this type of brake are also included in the operator's course on winter operations (see Section 1.17, Information on Air Nostrum's winter operations course).

As concerns the incident investigation, the main disadvantage of carbon brakes is that because they are so porous, they can absorb a large amount of moisture, which can cause freezing and seizing problems in brake assemblies, depending on the temperature. Transport Canada Civil Aviation (TCAA) has issued a Service Difficulty Advisory in this regard as a result of analyzing other cases. This advisory was reissued by the EASA as a Service Information Bulletin. It warns of this possibility and that it may result in tire failure and damage to the aircraft during landing due to the brakes locking (see Appendix A).

#### **1.6.5. Maintenance information**

The last maintenance check on the aircraft (600-hr, "A CHECK") was conducted on 14 January 2015, with 8003:42 hours on the aircraft.

The operator reported that the tire pressure had been checked the night before the incident. No maintenance activities had been conducted on the brakes in the month before. Brakes 1 and 4, which were the brakes on the affected tires, had gone through more than 500 cycles since they were installed.

Initially, the reason for the brakes locking and for the subsequent blowout of the no. 1 tire was thought to be a malfunction of the brake and anti-skid systems. Maintenance replaced the OBD BCV, which was common to the brakes on wheels 1 and 4, and

conducted an operational test and a functional test of the anti-skid system, both of which were satisfactory. The aircraft's manufacturer (Bombardier), after examining the data provided by the operator, determined that the most likely cause seemed to have been ice forming on the no. 1 wheel. There was also an abnormally high hydraulic pressure in the number 1 brake, which supported maintenance's decision to replace the OBD BCV.

### 1.7. Meteorological information

On the afternoon of 31 January, before the day of the incident, there were precipitations and snowstorms. The METAR provided by the LEPP Airport Weather Office (OMA) for 23:00 (when the airport closes) was as follows:

```
METAR LEPP 312300Z 33005KT 280V350 3500 RASN SCT007 BKN011 BKN022 01/01 Q1003=
```

The METAR indicates that there was a light 5-kt wind from 330°, varying from 280° to 350°. Visibility was 3500 m, there was moderated precipitations of rain and snow in or around the airport. There were scattered clouds (3 to 4 octas) at 700 ft, and broken clouds (5 to 7 octas) at 1100 and 2200 ft. The temperature was 1° C and the dewpoint was 1° C.

The airport reported that it stopped snowing a little while later.

The 20:00 aerodrome forecast (TAF)<sup>19</sup> was as follows:

```
TAF LEPP 312000Z3121/0121 33309KT 9999 SCT012 SCT030 TX04/0114Z TNM02/0106Z TEMPO 3121/0118 31015G25KT 3000 SHGRSN TS BKN020CB TEMPO 3121/0115 3000 -SN BKN008 BKN012 PROB30 3121/0115 0800 SN BKN003 BKN006 PROB40 TEMPO 0100/0109 33020G32KT =
```

In general, this report warned of showers, sleet and rain with storms until the afternoon on 1 February.

According to the OMA, it started snowing again on the morning of 1 February at around 05:30 (when the airport opens for operations).

The METARs and SPECIs<sup>20</sup> for the Pamplona Airport were as follows:

---

<sup>19</sup> TAF- Terminal Aerodrome Forecast

<sup>20</sup> SPECI- Special aviation weather report



METAR LEPP 010530Z 31013G23KT 280V340 9999 SN SCT020 BKN040 02/00 Q1006=

SPECI LEPP Q10537Z 32016KT 9000 SN SCT011 SCT015 BKN025 02/00 Q1006=

SPECI LEPP Q10549Z 32013KT 280V340 3000 SN BKN006 BKN020 01/01 Q1006=

METAR LEPP 010600Z 33012KT 7000 SN BKN007 BKN025 01/01 Q1006=

METAR LEPP 010630Z 31011KT 280V340 9000 -SN SCT015 BKN025 BKN035 01/01 Q1007=

A SPECI was issued at 05:37 informing that visibility was 9000 m, there was moderate snow in and around the airport with scattered clouds (3-4 octas) at 1100 and 1500 ft, and broken clouds (5-7 octas) at 2500 ft, the temperature was 2° C and the dewpoint 0° C. Another SPECI was issued at 05:49, informing that the visibility had worsened to 3000 m, the wind was variable in direction between 280 and 340°, there was moderate snow cover in and around the airport, broken clouds (5-7 octas) at 600 to 2000 ft, the temperature was 1° C and dewpoint 1° C. The METAR available to the crew was the one before their takeoff time (04:30)<sup>21</sup>, and according to it the wind was from the northwest at 15 kt, gusting to 27 kt, with a scattered cloud base (3-4 octas) at 3000 ft. It was very cloudy (5-7) octas at 4500 ft and visibility was 10000 m or higher. The temperature was 2° C and the dewpoint 0° C. The most accurate information closest to their takeoff time (06:13) was from 06:30<sup>22</sup>, according to which the wind was from the northwest at 11 kt, varying between 280° and 340°, visibility was 9000 m, it was snowing lightly at or near the airport, with a scattered cloud base (3-4 octas) at 1500 ft and broken clouds (5-7 octas) at 2500 and 3500 ft. The temperature was 1° C and the dewpoint 1° C.

The METARs for the Barajas Airport (LEMD) were as follows:

METAR LEMD 010600Z 31014KT 9999 FEW070 02/M04 Q1011 NOSIG=

METAR LEMD 010630Z 32008KT 9999 FEW070 01/M04 Q1012 NOSIG=

METAR LEMD 010700Z 31011KT 9999 FEW070 02/M04 Q1012 NOSIG=

METAR LEMD 010730Z 30009KT 9999 FEW070 02/M04 Q1013 NOSIG=

---

<sup>21</sup> SA 010430 30015G27kt 280V340 9999 SCT030 BKN045 02/00 Q1005=as noted by the crew in the OFP

<sup>22</sup> The information contained in a METAR is for the 30 minutes prior to the time it is issued.

Overall, this information is of no significance to the landing. Visibility was in excess of 10000 meters, there were few clouds at 7000 ft and 10-kt winds from the northwest at the time of landing (06:52).

### 1.8. Aids to navigation

The use of nav aids did not have any effect in this incident.

### 1.9. Communications

The most relevant communications between LEPP ATC, the crew of ANE8529, the operations coordination center (CECOA)<sup>23</sup> and the RFFS<sup>24</sup> (Rescue and Firefighting Services) are shown in Appendix A. According to the transcripts, the aircraft was cleared to take off at 06:11:55. In general, the conversations are consistent with the sequence of events described in sections 1.17.2 and 1.17.3 regarding the management of LEPP airport.

The communications with LEMD ATC after landing are not expressly included, since they do not add significant information to what is included elsewhere in this report in terms of the landing, taxi and inspections, first of the burst tire and then about the runway.

### 1.10. Aerodrome information

The Pamplona Airport (LEPP) is located 6 km south of the city of Pamplona, at an elevation of 459 m (1505 ft). The airport has a single 2405-m long, 45-m wide runway in a 15/33 orientation. The runway has a gradient of 0.52%, with the 33 threshold at a higher elevation than the 15 threshold. There is a single taxiway (TWY A) that measures just 150 m in length and connects the apron with the runway (see Appendix).

According to the AIP, the airport has the following equipment: 3 snow plows, two with urea sprayers and one without. The airport has a response plan for dealing with snow and ice in the winter, and the AIP lists the general operating conditions<sup>25</sup>. The plan is in effect from 1 November until 31 March. The airport's actions and the subsequent analysis of these actions in terms of cleaning the runway and the apron, as well as the measurement of braking efficiency, are detailed in Section 1.17.3, Information on the Pamplona Airport (LEPP).

---

<sup>23</sup> CECO A- Airport Operations Coordination Center

<sup>24</sup> RFFS- Rescue and Firefighting Service

<sup>25</sup> AIP Spain AD 1.2-1 Rescue and Firefighting Services and Snow Plan



The Madrid-Barajas Airport is located 13 km northeast of the city of Madrid, at an elevation of 609 m/1998 ft. The airport has four asphalt runways, 14R/32L, 14L/32R, 36R/18L and 36L/18R. Runway 14R/32L is 3998 m long and 60 m wide.

At the time of the incident, the runways in use for landings were 32L/32R (north configuration). The aircraft landed on runway 32L. Runway 14R/32L remained closed from 06:50 until 07:11, when the tower controller informed the control center that the runway was clear and in use.

### 1.11. Flight recorders

The aircraft had a Digital Flight Data Recorder (DFDR) and a Cockpit Voice Recorder (CVR). The information from the CVR was not available since the conversations from the incident flight were taped over. The information in the DFDR, however, was downloaded by the operator and was available to investigators.

The most relevant information from these data, along with the results of the FDM<sup>26</sup> analysis conducted by the operator, revealed the following:

The aircraft approached runway 32L at LEMD. There were no events of an unstabilized approach. The maneuver relied on the glide slope and localizer and was carried out at an approach reference speed of 130 kt. The aircraft approached into the wind, which was from approximately 325° at 33 kts at the start of the approach, and from 315° at 13 kt at the moment of landing. The main gear touched down at 06:51:30, and the nosewheel sensor was activated three seconds later. For seven seconds following the activation of the WOW sensor, there was no pressure in the brake assemblies, i.e. the crew did not apply the brake pedals. Despite this, the number 1 and 4 wheels did not turn. Brake pressure was subsequently applied to all four wheels (06:51:38), but the brake pressure shown for wheel 1 was higher than for the other three (see braking graph below). The pressure in the number 1 brake during the landing run was confirmed to have been 734 psi. The BTMS readings for brakes number 1 and 4 were 0-2.

---

<sup>26</sup> FDM- Flight Data Monitoring

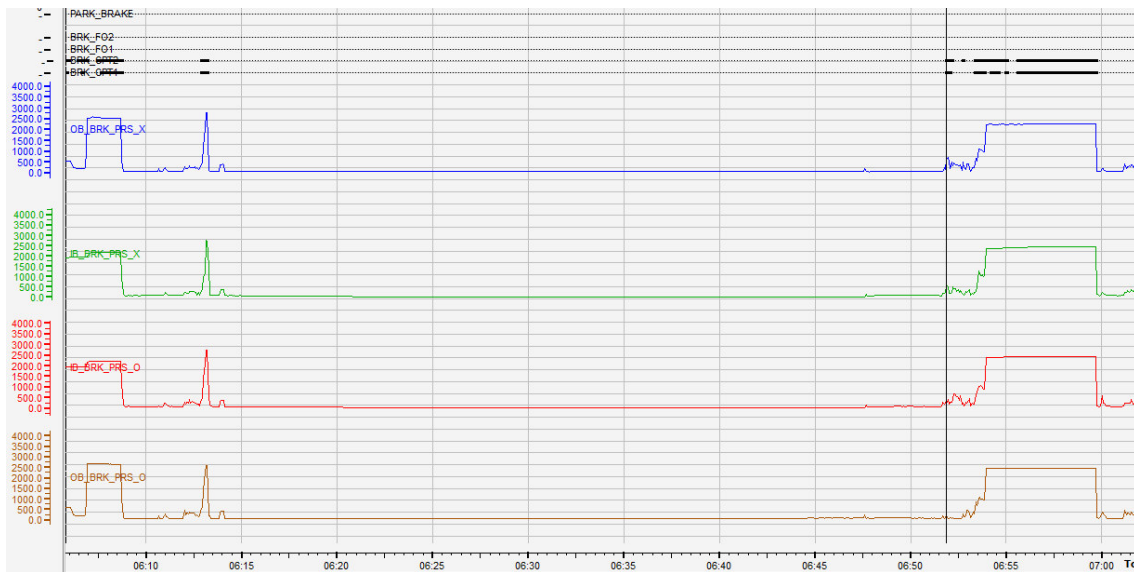

Figure 3. Braking graph

**1.12. Wreckage and impact information**

N/A

**1.13. Medical and pathological information**

N/A

**1.14. Fire**

There was no fire during the incident.

**1.15. Survival aspects**

There was no evacuation.

**1.16. Tests and research**

N/A

## 1.17. Organizational and management information

### 1.17.1. Information from the manufacturer and operator regarding snow or ice in the gear

According to the Airplane Flight Manual (AFM), a runway is regarded as contaminated when more than 25% of the runway's surface area, that is, the length and width required for operations (whether there are isolated spots or not), is covered by more than 3 mm (1/8 inch) of standing water or its slush equivalent.

The table below shows the equivalent thicknesses between standing water and slush.

| Depth of Standing Water | Equivalent Depth of Slush |
|-------------------------|---------------------------|
| 3.2 mm (0.125 in.)      | 3.8 mm (0.15 in.)         |
| 6.4 mm (0.25 in.)       | 7.4 mm (0.29 in.)         |
| 12.7 mm (0.50 in.)      | 15.0 mm (0.59 in.)        |

**Table 1. Contaminant thicknesses**

The standing water corresponds to the water that accumulates on the runway surface due to heavy rain or poor drainage. The slush is partially melted snow or ice with a high content of liquid water that can flow with a specific gravity estimated at 0.85. Slush is normally a transitional state that is only found at temperatures close to 0° C (32° F).

The maximum contaminant thicknesses authorized for operations in which contaminants cover a significant part of the runway, as specified in the limitations in Chapter 2 of the AFM, are:

| Contaminant    | Take-off           | Landing            |
|----------------|--------------------|--------------------|
| Standing Water | 12.7 mm (0.50 in.) | 19.1 mm (0.75 in.) |
| Slush          | 15.0 mm (0.59 in.) | 22.4 mm (0.88 in.) |
| Wet Snow       | 19.1 mm (0.75 in.) | 22.4 mm (0.88 in.) |
| Dry Snow       | 76.2 mm (3.0 in.)  | 95.3 mm (3.75 in.) |

**Table 2. Maximum contaminant thicknesses**

The "Normal Procedures - Consolidated Procedures" section of the AFM, as well as FCOM Supplement 2, "Operation on Contaminated Runways", contain the following:

3. Prior to take-off B. Taxi Check  
[...]

If conditions exist that can result in water saturated brakes, use light brake applications during taxi before take-off to reach approximately 3 units BTMS. DO NOT DRAG THE BRAKES. Warming of brakes will preclude the chance of water saturated brakes freezing at altitude and being locked for landing touchdown.<sup>27</sup>

4. After take-off A. Climb Check  
[...]

If taxi and/or takeoff were on ice, snow, or slush, unless weather conditions or performance requirements prohibit, delay retraction of the landing gear until excess water, snow or slush is thrown off by wheel rotation and/or slipstream force..<sup>28</sup>

The manufacturer was asked about the measures to take to avoid ice or slush build-up on the gear while taxiing, and the possibility that the brakes will freeze during the flight. The manufacturer replied that as the aforementioned procedures specify, it is sufficient to apply the brakes while taxiing and monitoring for three BTMS units, and to delay retracting the gear so that any excess water, ice or slush can be ejected by the rotation of the wheels or by the slipstream. According to the manufacturer, if three units are displayed on the brake temperature monitoring system, as specified in the FCOM for taxiing, this is equivalent to a brake temperature of between 104 and 137° C. The manufacturer's engineering department concluded that this temperature range is sufficient to melt any frozen water and to evaporate any residual mixture during the takeoff and the initial phases of the climb.

In addition, the Performance section of the AFM makes special mention of the fact that if conditions exist that can result in water saturated brakes the brakes must be applied a consecutive number of times to reduce the taxi speed from 20 to 5 kt<sup>29</sup>. The number of times they should be applied during the last NM or km of the taxi phase, before and not including the final stop before taking off, depends on the weight (in this incident, they should have been applied six times)<sup>30</sup>. It also recommends symmetric braking to ensure the brakes heat uniformly.

The Normal Procedures contained in FCOM 2 include (as shown in Section 1.6.4, Information on the carbon brakes) the operational advantages of carbon brakes, as well as their main disadvantage, namely wear at cold temperatures. These procedures add the following:

---

<sup>27</sup> "Normal Procedures - Consolidated Procedures" of the AFM, and FCOM Supplement 2, "Operation on Contaminated Runways"

<sup>28</sup> Part of the "Normal Procedures - Consolidated Procedures" in the AFM

<sup>29</sup> To reach 3 BTMS units

<sup>30</sup> 32997 Kg as per the load sheet

To maximize carbon brake life, avoid riding the brakes while taxiing. To maintain taxi speed use longer and firmer less frequent brake applications allowing the taxi speed to modulate above and below the target taxi speed. If taxi speed is too high and conditions (environmental, surface, passenger comfort, etc) permit, reduce speed by using one long, moderately firm brake application.

On landing, the carbon brakes wear, is primarily dependent on brake temperature. Therefore, a one steady firm brake application (until the aircraft has slowed down to a normal taxi speed) will heat carbon brakes up to their optimal operating temperature rapidly reducing wear during the final rollout and taxi in.

The FCOM<sup>31</sup> also contains the following points pertaining to carbon brakes:

When operating from wet, snow covered or slush covered runways or taxiways, or following overnight parking in known icing conditions, the following steps are applicable in order to prevent freezing of the wheel brakes:

- During taxi, use light brake applications to warm brakes before take-off. Monitor BTMS during taxi.
- Delaying gear retraction following take-off from slush or snow covered runways.
- When landing, carry out a positive landing to ensure initial wheel spin up and brakeout frozen brakes if frozen brakes are suspected.
- During the landing roll and subsequent taxi, use the brakes to prevent progressive build-up of ice on the wheels and brakes. Monitor BTMS during taxi.
- Following take-off or landing on wet, snow covered or slush covered runways and taxiways, tires should be inspected for flat spotting prior to the next flight.

In keeping with the manufacturer's requirements, the operator included the following in its winter operations courses:

- Taxi
- Keep brakes from freezing
- Heating the brakes keeps water-saturated brakes from locking on landing.
  - Aim for approximately BTMS 03.

---

<sup>31</sup> FCOM Supplement 2 "contaminated runway operations" and FCOM Supplement 12, "Cold weather operations" - "Procedures to avoid freezing the landing gear brakes"

— Apply brakes lightly

“DO NOT DRAG THE BRAKES”

- Delay retracting the gear

— Press the brake pedals shortly before retracting the gear in order to prevent GLD UNSAFE<sup>32</sup>

- After the incident, the training courses were changed to include a scenario that if the gear had contaminant fragments on departure, upon arrival there would be flat spots on the tires and ice fragments in the gear.

- Deicing and anti-icing inspection

— [...]

— Brakes should not be sprayed.

— It degrades braking capacity

— [...]

- Takeoff

— [...]

— Delay retracting the gear once airborne

- Landing

— Aim for a positive landing

- It forces the wheels to start turning

- Any ice formed on the brakes will fall off

---

<sup>32</sup> Ground Lift Dumping

## Procedures



The operator confirmed that the winter operations course was offered year-round so that crews could review certain topics if they wished to do so, since programming constraints meant that some crews had to take the course when cold-weather operations were not in effect.

In the course on differences between the CRJ900 and CRJ1000 that the operator gave to crews, they were reminded that on wet, contaminated runways in cold weather, a BTMS>03 was required on departure to keep the brakes from freezing once the gear was retracted.

### 1.17.2. Information from the ATC service provider at LEPP, Enaire.

The ATC log at the Pamplona Airport (LEPP) showed that the ATC service was provided starting at 05:00 and that airport operations commenced at 05:30. Also at that time, the runway configuration was changed to 33 in use due to the wind. There were no other incidents logged during the time period when the aircraft took off (see the local controller's statement in Section 1.18.3, Statement from the local controller at LEPP).

### 1.17.3. Information from Pamplona Airport (LEPP) personnel.

#### 1.17.3.1. General information provided by Pamplona Airport personnel.

On the day of the incident, the required inspections of the movement area were carried out and the inspection sheets were filled out. The runway inspections revealed the following:

INSPECCIONES OPERATIVAS DIARIAS TURNO MAÑANA

| ZONAS      | Accesos Limpios | Ausencia derrame de líquidos | Ausencia de FOD | Ausencia de Obstáculos cabecera 15 | Ausencia de Obstáculos cabecera 33 |
|------------|-----------------|------------------------------|-----------------|------------------------------------|------------------------------------|
| PISTA      | S               | S                            | S               | S                                  | S                                  |
| RODADURA   | S               | S                            | S               | S                                  | S                                  |
| PLATAFORMA | S               | S                            | S               | S                                  | S                                  |
| VIALES     | S               | S                            | S               | S                                  | S                                  |

| LEYENDA INSPECCIONES OPERATIVAS |            |
|---------------------------------|------------|
| S                               | SI         |
| N                               | NO         |
| -                               | No Procede |

INSPECCIONES OPERATIVAS MENSUALES TURNO MAÑANA Y TARDE

| TURNO  | Realizado Guiado | Realizado ensayo de Fricción | Realizado Control a Externos | Realizado inspección PCP |
|--------|------------------|------------------------------|------------------------------|--------------------------|
| MAÑANA | S                | S                            | S                            | S                        |
| TARDE  | S                | S                            | S                            | S                        |

Table 3. Operational inspections at the airport

According to these tables, the runway access points, taxiway and apron were clear with no FOD<sup>33</sup>. Two tests were performed during the morning shift to determine the coefficient of friction. According to communications with control, the first was performed at 05:24, before the airport opened. The results were 38-38-39 (medium-good).

The problems section indicated that the low-visibility procedure was in effect, and that following a request by Operations, the friction vehicle made a run at around 05:50, the results of which showed 31-36-33, indicating the presence of slush. The thickness of the standing snow was 12 mm.

According to the CECO Service Log, the following notable events were recorded on the day of the incident in the time before the incident aircraft took off:

|       |  |
|-------|--|
| 05:20 | Service open   |
| 05:21 | Operator X requests firefighters clean the section of apron up to the airplane.  |
| 05:50 | Second run of friction car.<br>1st coefficient of friction 39-38-38 Medium-Good<br>2nd coefficient of friction 31-36-33 M-MG-M |
| 06:09 | Departure of flight ANE 8529   |

Table 4. Extract from CECO Service Log

Other events were also logged on that day, such as complaints from passengers who were unable to access the terminal, measurements of friction coefficients, the creation of a SNOWTAM<sup>34</sup> and a snow and ice aerodrome notice.

At 05:10 on the following day, Operator X (the same as the previous day) requested

<sup>33</sup> FOD- Foreign Object Debris

<sup>34</sup> SNOWTAM- Report informing of runway contamination due to snow, ice or standing water.



that a path be cleared to the airplane's boarding gate, and later informed that they would not take off until both the apron and the runway were completely clear of snow. There were more entries that day involving clearing the runway.

*1.17.3.2. Analysis conducted by the Pamplona Airport. Proposed measures.*

After the incident, and since there had been a similar previous event involving ice in the landing gear<sup>35</sup>, the Pamplona Airport conducted a study on ice clearing operations at the airport in an effort to improve the processes used at the airport. The data obtained by the airport to carry out this analysis are shown below:

The 20:00 aerodrome forecast (TAF) called for periods of brief rain and snow from the night of 31 January until the afternoon of 1 February. On the morning of 1 February, it started to snow at around 05:30, when the airport opened. The snowfall melted with water, forming a layer of slush on the ground, with different levels of contamination depending on the type of pavement.

- For the asphalt concrete (runway), due to its higher conductivity, there was slush in isolated areas.
- For the hydraulic cement (apron), due to its lower conductivity, the contamination was due to slush.

The main snow removal activities are carried out by the airport's RFFS, which consists of four firefighters and a crew chief.

The RFFS carries out the following tasks:

- The Preventive Tasks include applying de-icing chemicals (urea) and preventing snow build-up in anticipation of temperature drops or further rain or snow fall.
- The Corrective Tasks include removing contaminants from the runway.
- The Verification Tasks include inspecting the movement area.
- The Tasks to Measure the Coefficient of Friction include: measuring the friction, water loading and the depth of contaminants. The coefficient of friction is measured only by the crew chiefs, since they are the only ones with the training required to do so.

---

<sup>35</sup> Also investigated by the CIAIAC, see A-002/2007

During the day on 1 February 2015, the firefighters carried out corrective and verification tasks and measured the coefficient of friction. These tasks were performed only on the runway and apron.

The night before, the RFFS removed snow until 22:30 and applied a large amount of urea throughout the movement area and access points before operations stopped at 22:45. This was all done in response to the information contained in the METARs, SPECIs and TAFs published by the airport's weather office.

Based on findings taken from the analysis conducted by LEPP airport officials:

- CECO, at the TWR's request, asked the RFFS to measure the coefficient of friction, which was done at 05:17. They communicated the values obtained accordingly.
- To allow passengers to board, a snow plow made runs between the aircraft and the terminal to clear a path for passengers.
- CECO, again at the TWR's request, asked the RFFS to measure the coefficient of friction, which was done at 05:46. They communicated the values obtained accordingly.
- 23 minutes elapsed between the last friction measurement and the aircraft's departure, during which it continued to snow moderately.

The values reported to CECO were:

|                       | 1 <sup>st</sup> reading | 2 <sup>nd</sup> reading |
|-----------------------|-------------------------|-------------------------|
| Average of first run  | 39                      | 31                      |
| Average of second run | 38                      | 36                      |
| Average of both runs  | 38                      | 33                      |

**Table 5. Values recorded by the RFFS**

The "Adverse weather procedure" at LEPP includes the steps to take depending on the depth of the snow (see table below).

| Snow depth values (cm) | Action to take | Operativity                      |
|------------------------|----------------|----------------------------------|
| Between 0 and 1,5      | Apply urea     | As per readings                  |
| Between 1,5 and 2      | Snow removal   | As per readings                  |
| Between 2 and 5        | Snow removal   | Possible closure of the runway   |
| More than 5            | Snow removal   | Closed runway for cleaning works |

**Table 6. Steps to take depending on snow depth**

According to AESA’s “Technical Instruction for Carrying out an Adverse Weather Plan”, operations must be suspended in the following cases:

| Contaminant          | Depth (cm)  |
|----------------------|-------------|
| Melting snow (slush) | >1,27       |
| Wet snow             | >2,5        |
| Dry snow             | >5          |
| Packed snow          | Not limited |
| Hard Ice             | Not limited |

**Table 7. Actions based on depth of contaminant**

The conclusions reached by airport officials after their analysis of the incident include the following:

- The airport’s procedure did not consider criteria involving the use of the vehicle employed to measure the coefficient of friction based on the type of contaminant.
- The point where the contaminant depth was measured was chosen by the RFFS Crew Chief using the least favorable selection criterion. According to the procedure, the measurement should be taken at 300 to 400 meter intervals over the length of the runway, approximately 3m from the runway centerline, and an average value should be calculated for each third of the runway.
- The contaminant depth was determined at the same time as the second evaluation of the coefficient of friction.
- The contaminant depth on the taxiway and apron, though not measured, was deemed to have been higher than on the runway. There were also cordons of snow along the taxi route taken by the aircraft. As a result, contaminants could also have built-up on the gear during the taxi phase.

After their internal analysis, LEPP airport officials proposed the following steps to take:

- Evaluate the possibility of limiting contaminant depth on taxiways and the apron, or at least report the contaminant depths and type, in case they exceed the runway values or the contaminant type is different.
- There should be no snow cordons along the path to be taken by the aircraft. The possibility of reducing the maximum height of this contaminant type on the runway should also be evaluated.
- There is an urgent need to improve personnel training (measuring contaminant depth, contaminant depth parameters, how to take readings in the vehicle used to measure the coefficient of friction, monitoring conditions and changing the information provided, etc.).
- The time that elapses between inspecting the surface and the aircraft operation should be minimized. The condition of the surface should be inspected before the operation and suitable measures should be taken if the conditions change significantly. The runway should be monitored continuously to identify any changes in its condition.
- The RFFS's tasks in the Winter Plan should be analyzed to ensure they are compatible with maintaining the level of protection.

#### ***1.17.4. Information on the Adolfo Suárez- Madrid Barajas Airport (LEMD)***

According to the report from the service manager, at 06:55 the LEMD control tower reported a possible blowout on the aircraft with callsign ANE8529, landing on runway 32L. Three minutes later, the COAM<sup>36</sup> confirmed the tire blowout and the crew requested a parking stand near the runway and a tow tractor, though in the end the aircraft taxied under its own power to the assigned stand (5). After analyzing the situation, the service manager did not deem it necessary to declare a local alarm. Once the aircraft was at its stand, the tower controller confirmed the presence of FOD on the runway and the TOAM was asked to clear and inspect the runway. The controller also coordinated with ACC and CGA<sup>37</sup> to leave the runway inoperative until it was free from FOD.

---

<sup>36</sup> COAM- Movement area operations coordinator (in charge of marshallsers)

<sup>37</sup> CGA- Airport Management Center

A metal piece from the main gear, a chunk of tire and three fist-sized ice fragments were found (see Photograph 6).



**Photograph 6. Debris found on the runway after the landing**

The CGA informed the RFFS of the incident, which reported to stand 5 with two vehicles. The RFFS confirmed that the number 1 wheel on the main gear had burst and part of a metal plate was loose (see Photograph 7).



**Photograph 7. Landing gear after the aircraft reached the parking stand**

Since the gear had not overheated, the RFFS left the scene under the control of the TOAM and returned to the station. The passengers were still on the aircraft.



CEGRA<sup>38</sup> was informed and asked to relay the information to the Pamplona Airport.

The figure below shows where the debris was found on the runway.

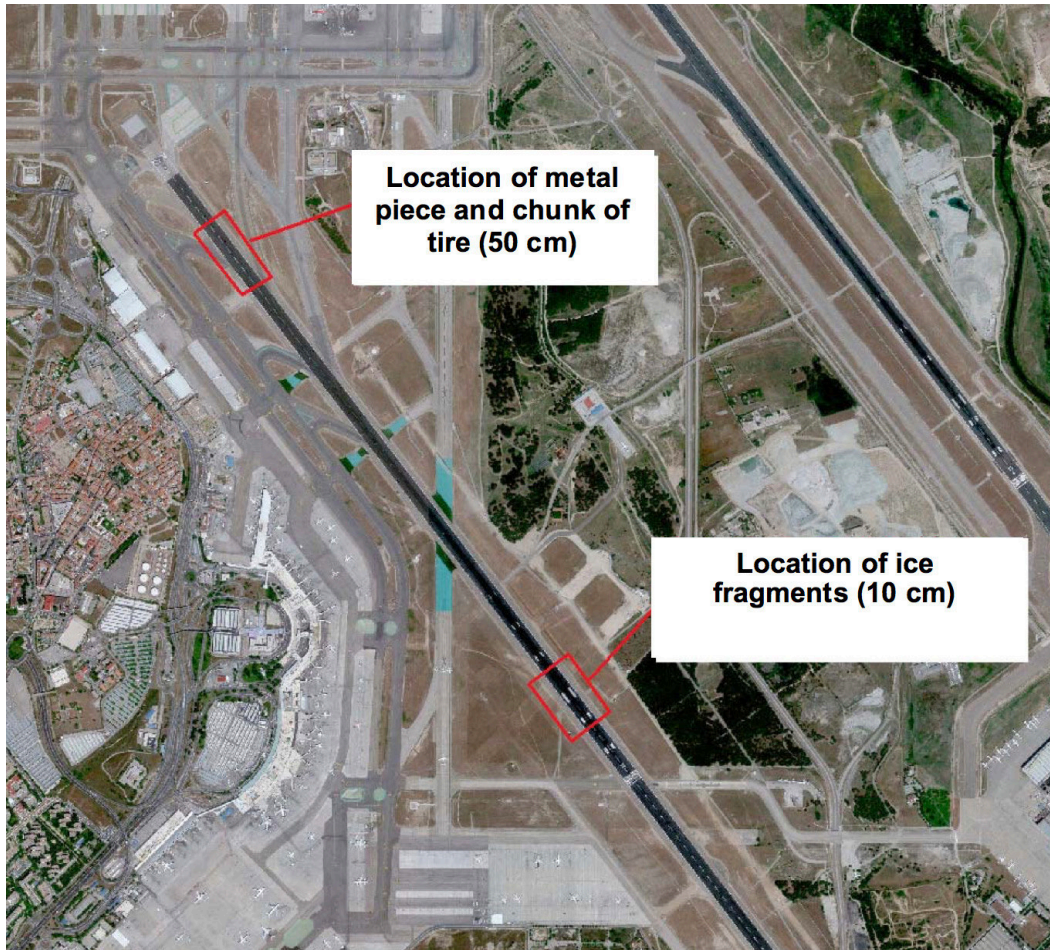

Figure 4. Locations of debris at LEMD

#### 1.17.5. Information from the ATC services provider at LEMD, Enaire

The incident was recorded in the ATC log at LEMD, coincident to what airport had exposed, noting that aircraft ANE8529 had reported a possible blowout after landing on runway 32L. The blowout was confirmed and the runway was declared inoperative until it could be inspected. During this inspection, various parts from the landing gear and chunks of ice were found on the runway.

---

<sup>38</sup> CEGRA- Aena Aeropuertos Network Management Center

## 1.18. Additional information

### 1.18.1. Statement from the crew

On 31 January, the crewmembers finished their work day at LEPP at about 17:00 local time. The aircraft had not arrived yet from its daily rotation. It started snowing in the afternoon but it did not stick in the city. When they woke up the next day, it was still snowing but there were no problems on the road. When they arrived, there wasn't snow covering the aircraft. On the apron there was snow mixed with ice pellets. It would snow for a little bit, then stop for five to ten minutes, and then start snowing again.

At the airport, the mechanic told them he was going to clean the landing gear due to the previous day's landing. During the walkaround, the first officer noticed that the gear "looked good". The airplane was deiced at the parking stand (2), and passenger boarding began just as it stopped snowing. The runway had been cleared throughout the night but not the apron. Only type-I deicing is done at the LEPP airport. With type I, the holdover time (HOT)<sup>39</sup> is very short (11 to 18 minutes, according to the tables published in the operator's documentation<sup>40</sup>). So as not to let their HOT expire, they waited until it stopped snowing before asking to board the passengers and deicing the aircraft.

The crew entered the following entry in the aircraft log:

"DEICING AT PNA<sup>41</sup>. WAITED FOR SNOW SHOWER TO PASS OVER SO AS NOT TO WASTE HOT WITH TYPE-I FLUID"

They had been informed that the braking efficiency on each third of the runway was Medium, Medium and Medium to Poor on runway 33. They did some conservative performance calculations by using the Medium to Poor value for the braking efficiency. Both seemed to recall that the tower controller had given them a value of 0.32.

The crew did not have information on the condition of the runway (no MOTNE<sup>42</sup> or SNOWTAM) since the airport was closed when they arrived. They had the 02:00 TAFOR and the 04:30 METAR. Both crewmembers admitted that "as pilots", they were more concerned about the possibility of ice on the wings than in the gear. They asked how long it would take to clear the runway again and they were told 25 to 35 minutes. The

---

<sup>39</sup> (HOT)-Holdover Time – estimated time during which the deicing/anti-icing fluid is effective in preventing the formation of frost or ice and the accumulation of snow on treated surfaces. The HOT begins when the approved deicing fluid is first applied and lasts until this fluid is no longer effective. The fluid is considered to lose its effectiveness when its capacity to absorb more precipitation is exceeded.

<sup>40</sup> Holdover Time (HOT) guidelines for winter 2014-2015

<sup>41</sup> PNA-IATA code of Pamplona Airport

<sup>42</sup> MOTNE- Meteorological Operational Telecommunications Network Europe

crew requested a new braking performance test. The ground could be seen through the slush that was present, though the ground vehicles left tracks in the slush.

When they started taxiing it began to snow again. There is a short taxi distance between the apron and the threshold at LEPP, about 5 minutes (300 m).

The crew stated that they did not carry out the procedure to achieve 3 BTMS units before takeoff. They had not thought to do the procedure since it would have required seven braking cycles from 20 to 5 kt, unfeasible on a taxi run as short as the one at LEPP. They also noted that they could not delay the gear retraction, as specified in the procedure, because they did not want to go into the clouds with the gear down, and because it was "dangerous" at an airport with LEPP's geography. The crew admitted they were unaware of the porosity of carbon brakes.

The captain was the pilot flying (PF). At 1000 ft AGL they encountered icing conditions. At 1500 ft they entered the clouds and "cleaned the airplane"<sup>43</sup>. They also received a green ice detector indication (ICE<sup>44</sup>) since the anti-ice system was on.

When they reached Madrid, they requested runway 32L to minimize the taxi distance (they had been cleared for 32R). They made a stabilized approach and opted to land long so they could leave via exit L-6 and reduce the taxi distance.

The landing was normal but immediately after landing, they felt vibrations (before applying the brakes). The first officer said, "The brakes are frozen! Are you braking?" But the aircraft was braking well without excessive vibrations, similar to going over rumble strips on a road. The vibrations did not affect the steering. There were no antiskid or OB BRAKE PRESS<sup>45</sup> messages. The captain added that he barely applied the brakes and that the airplane slowed down by itself.

Both pilots noted that they did not make a positive landing at LEMD because they did not think the weather conditions at LEPP warranted such a landing.

Then exited the runway via L-5, changed to the GND frequency and yielded to two aircraft from another operator. The second of these aircraft called the TWR to report that there was a problem with a gear door on the Air Nostrum. The crew then requested a nearby parking stand. They continued taxiing to stand 5 (which is opposite the 32L exit), since the aircraft was not having any problems moving.

---

<sup>43</sup> Retract the gear and flaps

<sup>44</sup> Normal ice detection indication

<sup>45</sup> Outboard brake pressure



Training on winter operations is held during refresher training once a year, and, according to the crew, not always on the most suitable dates (the captain took the course in summer). When they were interviewed, the crew commented that the operator had made the course available on its e-learning platform to review. The crew noted that the course was designed for the CRJ200 and CRJ900, but not for the CRJ1000.

The crew returned to LEPP the day after the incident, but conditions were worse and, in light of their experience the previous day, they opted to delay the flight for three hours.

#### ***1.18.2. Statement from the mechanic involved in deicing***

The maintenance mechanic at LEPP reported that the aircraft had spent the night at the airport and when it was taken to the stand, there was a lot of packed snow on the main gear and nose gear. The gear was cleaned by hand and using a brush, leaving only small bits of ice in hard to reach areas that melted overnight. In the morning, the same technician was present during the deicing process and start-up. Though the apron was not completely clear of snow, no snow accumulated on the aircraft since it taxied very slowly to the threshold and the tires did not splash any debris upward. Since there was no snow at the destination airport, the mechanic thought that all of the snow built up on the gear during the takeoff run.

#### ***1.18.3. Statement from the local controller at LEPP***

According to the LEPP controller, the service opened for operation as usual, and since it had snowed the night before, he asked the CECOA to obtain braking efficiency readings and to check the condition of the runway. The readings were taken and the airport was operational at 05:30, which is more or less the usual time. In the first radio exchange, the crew were informed of the conditions at the airport and of the results of the braking efficiency reading (there was slush and the braking efficiency was medium to good in the first reading, taken at about 05:30). The crew, however, seeing the condition of the apron, asked if the runway was going to be cleared. After speaking with operations, the controller was told that it was not necessary because there was slush on the runway, and it melted when a vehicle passed over it, but that if the crew wanted it cleared, it would be. This information was relayed to the crew, adding that it would entail some delay, so the crew requested a new braking efficiency reading just before their departure. Arrangements were made with the crew and the runway vehicle to determine the right time to take the readings (taking into consideration the times to both take the reading and do the calculation as well as the time to deice the aircraft) so that the aircraft could taxi immediately after being deiced. The results of the reading (taken

at about 06:00) were, as the controller recalled, medium in two thirds and good in one, or medium on all three thirds of the runway<sup>46</sup>.

The aircraft took off normally, with the crew making no reports regarding the condition of the runway.

#### **1.18.4. Statement from the RFFS Chief at LEPP**

When he went on duty, he read in the log that urea had been applied as a preventive measure on the night of 31 January 2015.

When he inspected the runway and apron, he saw there was slush, but it was only 12 mm deep, which meant it could not be removed with a plow, which requires a contaminant depth (in this case slush) of 5 cm<sup>47</sup>, as specified in the local winter plan. He conducted a friction test between about 05:15 and 05:20 at Operations' request. The friction vehicle made a new run between about 05:50 and 06:00, again at Operations' request. He did not recall if the tower was told of the presence of slush after the first or second set of readings, which the tower then relayed to the aircraft.

At about 10:00, the friction measurement vehicle made another run. The contaminant depth, in this case snow, was sufficient to allow the use of snow plows, which started removing snow, primarily from the runway and apron, until approximately 13:45.

### **1.19. Useful or effective investigation techniques**

N/A

---

<sup>46</sup> ATC reported that the braking efficiency by runway thirds was: medium, medium-good and medium.

<sup>47</sup> The minimum depth is in fact 1.5 cm. It is unclear if there was a mistake when specifying this parameter.

## 2. ANALYSIS

On 31 January 2015, the aircraft landed in LEPP on its final flight of the day, reaching the parking stand with a considerable amount of snow in the landing gear. According to the maintenance technician, the snow was cleaned by hand, with only some snow remaining in hard to reach places that melted during the night.

The aircraft spent the night there. It snowed all that night and it was still snowing the following day, though intermittently. The crew had the 04:30 weather information, though there would be no significant changes with respect to the parameters at its departure time. According to the crew, there was snow mixed with ice pellets, though there was no snow build-up on the airplane. The snow plows had been working to clear the runway, but not the apron. The crew asked the LEPP tower controller to have the runway cleared and to measure the braking efficiency again. The ground was visible through the slush, though the vehicles left a trail when they drove over it. The distance between the apron and the runway was short, and once the aircraft was deiced, the crew proceeded to taxi to the runway. They took off normally at 06:13 from runway 33 at the Pamplona Airport.

The flight was uneventful but upon landing at the destination airport the crew felt vibrations coming from the main gear, which they initially identified as a blowout. The crew asked the tower controller for a visual check of the condition of the gear, and the crew of an aircraft from another operator informed them that something was wrong with the left gear door. The crew asked the control tower for a nearby parking stand. Once there, it was confirmed that the outboard left tire (number 1) had burst and had a flat spot before the blowout. The outboard right tire (number 4) also had a flat spot. There were chunks of white ice stuck to the landing gear legs, and debris from a tire and from the gear door, as well as several pieces of white ice were found on the runway where the aircraft had touched down.

Initially the cause was thought to be the anomalous operation of the braking system and the anti-skid system. Maintenance replaced the OBD BCV, which is common to the brakes on the 1 and 4 tires, and operational and functional tests of the anti-skid system were conducted, the results of which were satisfactory. The aircraft manufacturer (Bombardier), after reviewing the data provided by the operator, concluded that the most likely cause seemed to have been the formation of ice in wheel number 1. There was also an abnormally high hydraulic pressure in brake number 1, which supported the decision by maintenance to replace the OBD BCV.

### 2.1. Analysis of the braking system on the aircraft

The main landing gear consists of two gear structures mounted underneath the wings. Each structure includes a strut and two identical tires that support the aircraft's weight.

The wheels are numbered from left right, with the number 1 wheel being the outboard left wheel and the number 4 being the outboard right wheel. The gear retracts inward into two wells or bays for the wheel in each wing and in the fuselage. There is a door that is attached to each gear assembly and that functions as a cover when the gear is retracted. This door does not cover the outboard wheels on the main gear, which are outside the fairing when the gear is retracted and are not "protected" by the door. Maintenance reported that the gear was cleaned by hand and with a brush when it arrived the night before the incident, and again before being dispatched.

The aircraft taxied from the apron (which had not been cleared of slush) to the runway, which had slush that was not over the depth limit that would require removal, according to airport officials, though it was deep enough that it left tracks when vehicles passed over it. The aircraft took off from runway 33 and according to the crew, they encountered icing conditions at 1000 ft AGL, and at 1500 ft the aircraft penetrated the clouds. The crew retracted the gear and flaps and the ice detector reading turned green because the anti-ice system was engaged.

After takeoff, the flight proceeded normally. During the landing, the crew did not apply braking pressure, and yet wheels 1 and 4 did not rotate, meaning it was likely that both the brake assemblies and the wheels were effectively locked. The crew did later apply braking to all four wheels, but the pressure shown for the number 1 wheel was higher than for the other three. The pressure in brake number 1 was confirmed to have been 750 psi during the landing, but this was not sufficient pressure to cause the tire to skid and then to blow out. The BTMS readings for brakes number 1 and 4 during landing were 0-2 units, which are not excessively high.

The aircraft was equipped with carbon, instead of steel, brakes. The main drawback of carbon brakes over steel brakes is that due to their porosity, they can absorb large amounts of moisture. If this happens, the moisture can soak the brakes, which can then freeze if the temperature conditions are right. This situation can lock the brakes, which could potentially result in a tire blowout during the landing.

In light of the above information, it is likely that some of the slush encountered by the aircraft while taxiing and during the subsequent takeoff run made its way into the gear bay and attached to the gear structure due to its viscosity. When the gear was retracted, wheels number 1 and 4 remained in a lower position that is less protected against low temperatures while in flight. As a result, the slush could have fallen under the force of gravity to the brake assemblies, soaking them in parts and forming deposits that later froze.

According to currently established procedures (both in the AFM and the FCOM), if the runway is contaminated, and thus if the possibility of the brakes freezing exists, the following must be performed:

3. Prior to take-off B. Taxi Check  
[...]

If conditions exist that can result in water saturated brakes, use light brake applications during taxi before take-off to reach approximately 3 units BTMS. DO NOT DRAG THE BRAKES. Warming of brakes will preclude the chance of water saturated brakes freezing at altitude and being locked for landing touchdown.<sup>48</sup>

4. After take-off A. Climb Check  
[...]

If taxi and/or takeoff were on ice, snow, or slush, unless weather conditions or performance requirements prohibit, delay retraction of the landing gear until excess water, snow or slush is thrown off by wheel rotation and/or slipstream force."<sup>49</sup>

The Performance section of the AFM made special mention of the fact that if conditions exist that could lead to saturated brakes, the brakes must be applied a consecutive number of times to reduce the taxi speed from 20 to 5 kt. The number of times they should be applied depends on the weight<sup>50</sup> (in this incident, they should have been applied six times based on the actual weight shown in the load sheet) during the last NM or km of the taxi phase, before and not including the final stop before taking off. It also recommends symmetric braking to ensure the brakes heat uniformly.

When operating on wet or contaminated runways, the manufacturer recommended the following to avoid brake freezing:

- During taxi, use light brake applications to warm brakes before take-off. Monitor BTMS during taxi.
- Delaying gear retraction following take-off from slush or snow covered runways.
- When landing, carry out a positive landing to ensure initial wheel spin up and brakeout frozen brakes if frozen brakes are suspected.
- During the landing roll and subsequent taxi, use the brakes to prevent progressive build-up of ice on the wheels and brakes. Monitor BTMS during taxi.
- Following take-off or landing on wet, snow covered or slush covered runways and taxiways, tires should be inspected for flat spotting prior to the next flight.

---

<sup>48</sup> "Normal Procedures - Consolidated Procedures" of the AFM, and FCOM Supplement 2, "Operation on Contaminated Runways"

<sup>49</sup> Part of the "Normal Procedures - Consolidated Procedures" in the AFM

<sup>50</sup> To reach the 3 BTMS units required.

The manufacturer believed that complying with the instructions in its procedures for taxiing and the subsequent takeoff were sufficient to avoid the possibility of having the brakes freeze during a flight.

Several of these recommendations regarding the use of this type of brake were also explicitly contained in the operator's course on winter operations. Later added to the course was information regarding the presence of flat spots on the tires and ice residue in the gear if there was contaminant residue on the gear on takeoff (in line with the contents of the EASA Safety Information Bulletin).

In light of the preceding information, the manufacturer's and operator's procedures are deemed to have contained the information needed to keep the brakes from freezing if the required conditions were present. However, while these procedures make explicit and continuous references to the disadvantage of brake wear in cold temperatures, they do not explicitly warn about the drawback posed by the porosity of the carbon material in these brakes, information that would be useful for crews and maintenance personnel. This drawback is reflected in the EASA's Safety Information Bulletin as a consequence of the analysis by Canada's Civil Aviation Authority (the State of manufacture) of similar cases, which recommended as a best practice the dissemination of this information among interested personnel. As a result, two safety recommendations are issued in this regard and detailed later.

### **2.2. Analysis of the crew's actions**

In contrast to the instructions in the procedures described above, the crew did not comply with the procedural requirement of getting 3 BTMS units prior to takeoff. They stated that this would have forced them to do seven braking cycles (actually six by procedure for their weight) from 20 to 5 kt, unfeasible over the short taxi distance (about 300 m) used when taking off from the Pamplona Airport. They also argued that they could not delay retracting the gear as specified in the procedure because they did not want to "go into the clouds" with the gear out and because, as they stated, it would be "hazardous" at an airport with a geography like Pamplona's. In this regard, the CIAIAC believes that if it is impossible to comply with a procedure, crews should report this and the operator should write a procedure specific to the airport in question.

When landing, the crew did not make a positive landing, as specified in the applicable procedures. When asked why they did not carry out this maneuver, both replied that they did not think the weather conditions at LEPP warranted such a landing, although when they felt vibrations during the landing roll, the first officer immediately associated them with that problem.

The crew had taken the winter operations course, as scheduled, in July and August 2014. The operator confirmed that the winter operations course is available year-round so that crews can review the material even if the course, for scheduling reasons, is given before the winter season. As a result, a safety recommendation will not be issued in this regard.

Both crewmembers admitted to not knowing about the porosity of carbon brakes. It is likely that because of their ignorance of this key drawback to carbon brakes when moisture is present, because the information provided by the airport about the friction coefficient was not particularly worrisome (medium to good) and because, according to their statement, they were more focused on and worried by ice build-up and formation on the lift surfaces, they paid less attention or gave less importance to the specific operation involving the brakes.

The above notwithstanding, the weather conditions at the airport on the day of the incident were similar to those described both in the manufacturer's procedures (Cold Weather Operations and/or Contaminated Runway Operations) and in the operator's courses. The crew stated that they could not carry out those procedures due to the limitations at the airport in terms of the taxi distance and the initial climb. As a result, one safety recommendation is issued in this regard.

### **2.3. Analysis of the actions taken by the Pamplona Airport (LEPP)**

The main tasks involving snow removal are carried out by the airport's RFFS, which has a staff of four firefighters and one crew chief. On that day the RFFS removed snow and verified and evaluated the coefficient of friction. These tasks were only carried out on the apron and runway.

The night before, the RFFS removed snow until 22:30 and applied a large amount of urea throughout the movement area and access points before operations stopped at 22:45.

The morning of the incident, the RFFS measured the coefficient of friction at 05:17 and a snow plow removed the snow between the aircraft and the terminal, clearing the passenger walkway. The coefficient of friction was measured once more at 05:46, yielding values of 39-38-38 and 31-36-33. Between the final friction measurement and the start of the aircraft's operation, 23 minutes elapsed, during which it continued to snow moderately. This time is long enough for conditions on the runway to have changed significantly.



The information relayed about the coefficient of friction did not correspond to the values for each third of the runway<sup>51</sup>, but rather to the average of the first run, the second run and the average of both runs. The airport concluded that the procedure did not consider criteria involving how the coefficient of friction measurement should be applied depending on the contaminant type. The point where the contaminant depth was measured was chosen by the RFFS Crew Chief using the least favorable selection criteria. The contaminant depth was determined at the same time that the second evaluation of the friction coefficient, and the contaminant depth on the taxiway and apron, believed to have been greater than on the runway, was not measured. There were also snow trails along the taxi path taken by the aircraft, meaning that contaminant build-up could also have occurred during the taxi phase.

On the day of the incident another operator asked that the apron be cleared up to the airplane, and passengers complained that it was difficult to access the terminal. The information provided by the airport indicated that there were not enough personnel to remove snow. The day after the incident, at about the same time (05:10), the other operator also asked that a path be cleared so that passengers could board the airplane, and later informed that they would not take off until both the apron and runway were completely clear of snow. Further snow removal activities were recorded on that day.

According to the airport's procedure, when the snow is 0 to 1.5 cm deep, the method used on the runway is to apply urea. The aircraft manufacturer's limits in terms of the maximum contaminant depth allowed to cover a significant part of the runway is 1.5 cm for slush. According to the EASA's Technical Instructions, if more than 1.27 cm of slush is present, operations have to be suspended. The RFFS reported a slush contaminant depth of 12 mm. In light of these figures, the aircraft's operation would have been within limits, the snow did not have to be removed and the limit specified by the EASA for suspending operations was not exceeded.

Deficiencies were detected, however, in how the procedures in the Winter Operations Plan were applied, as well as in the training given to the personnel (RFFS) involved in both taking readings and clearing the movement area (maneuvering area plus apron). After conducting its analysis, the airport proposed taking certain actions, but as of this writing, the CIAIAC is unaware of what measures, if any, have been adopted. Two safety recommendations are thus issued in this regard.

---

<sup>51</sup> The airport procedure specifies that the contaminant depth is to be measured every 300-400 m along the runway, approximately 3 m away from the centerline, with an average depth being calculated for each third of the runway.



### 3. CONCLUSIONS

#### 3.1. Findings

An analysis of the information available yielded the following findings:

- The aircraft's documentation was valid and in force.
- The controllers had valid and in force licenses, ratings, rating endorsements and medical certificates.
- The pilots had valid and in force licenses, ratings, and medical certificates.
- The crew had experience on the aircraft type.
- The crew had taken the operator's Winter Operations course.
- When the aircraft landed at the Pamplona Airport (LEPP) the day before on its last flight of the day, there was snow build-up on the gear, which was cleaned manually by maintenance.
- The snow was cleared from the runway until 22:30, and a large amount of urea was sprayed throughout the movement area before the end of operations (22:45).
- It snowed that night and it was still snowing off and on the following morning.
- The next day the braking efficiency was measured when the airport opened, and then again at the request of the crew.
- A snow plow cleared the passenger walkway to the aircraft on the apron.
- The taxi distance from the apron to the runway was very short, about 300 m in total.
- The aircraft was deiced and the aircraft taxied to the threshold.
- 23 minutes elapsed between the last braking efficiency reading and when the aircraft started to taxi. During this time, it continued to snow moderately.
- The crew stated that there was slush on the apron, and that both the runway and taxiway had slush trails left by passing vehicles.
- The operator has not established a special procedure to operate in LEPP with contaminated runway and operations to reach 3 BTMS units.

- Another operator requested that the walkway from the terminal to the aircraft be cleared, and the following day it insisted that both the apron and the runway be cleared of snow before it started its operations.
- The airport reported that the slush was only 12 mm deep, and that procedurally it was not required to clear the slush.
- The contaminant depth was determined following the second reading of the coefficient of friction, and was not done as per the procedure in place, according to airport officials.
- The coefficient of friction was not determined as per the procedure and the average reading per run was provided instead of the reading per third.
- The CRJ1000 aircraft has carbon brakes instead of the traditional steel brakes.
- The main drawbacks of carbon brakes are that they wear fast at low temperatures and they absorb moisture.
- Because they are porous, carbon brakes are able to absorb a large amount of moisture.
- This moisture can dampen the brakes, which can freeze, leading to locked brakes, which can potential blow out the tires during landing.
- The crew were unaware of the drawbacks of carbon brakes.
- The aircraft procedures when operating with carbon brakes are different from those for steel brakes.
- The manufacturer offers several guidelines to avoid premature wear of carbon brakes and to keep them from freezing if they are saturated with water.
- The manufacturer does not explicitly warn of the drawbacks of carbon brakes (porosity) and their possible consequences.
- Its guidelines include reaching 3 BTMS units while taxiing by braking from 20 to 5 knots (six times in the incident considered in this report) during the last NM or km of the taxi phase in order to keep the brakes from freezing if they are saturated with water.
- The crew did not carry out this procedure to attain 3 BTMS units while taxiing because the taxi distance was insufficient.

- Another guideline if water-saturated brakes are suspected is to delay retracting the gear and to make a positive landing at the destination to help detach any remaining contaminants
- After takeoff, at 1000 ft AGL, icing conditions were present, and at 1500 ft the aircraft penetrated the clouds. The crew retracted the gear and flaps. The ice detector reading turned green because the anti-ice system was engaged.
- The crew did not delay retracting the gear because they were penetrating the clouds and they thought it dangerous due to the geography around LEPP.
- The operator does not have a specific procedure for operating at LEPP in contaminated runway conditions. There are also operational limits on delaying the retraction of the gear.
- The flight was uneventful until the landing, when the crew felt vibrations coming from the gear.
- The wheels that remain outside the aircraft after being retracted (nos. 1 and 4) were affected.
- The no. 1 wheel had burst and there were signs of a flat spot. The no. 4 wheel had a flat spot.
- The manufacturer cautioned in its procedures to check the tires for flat spots before the next flight if taking off from contaminated runways.

### **3.2. Causes/Contributing factors**

The incident was caused primarily because part of the slush encountered while taxiing and during the subsequent takeoff run is thought to have made its way into the landing gear bays, adhering to the components there. When the gear was retracted, wheels number 1 and 4 were in a lower position and thus more exposed to low temperatures during the flight. As a result, the slush deposited on the gear could have fallen due to gravity to the brake assemblies before freezing in place.

The following contributed to the incident:

- Improper snow clearing operations at the Pamplona Airport, which resulted in the presence of slush on the apron and cordons of slush both on the taxiway and on the runway.

- The improper operation taken by the crew when taking off from a contaminated runway, namely: heat the brakes; delay gear retraction to facilitate the detachment of the contaminant; make a positive landing at the destination to detach any remaining frozen contaminant.

#### 4. SAFETY RECOMMENDATIONS

The aircraft had carbon brakes installed instead of the more common steel brakes. The operating procedures for carbon brakes differ from those for steel brakes. Carbon brakes are more efficient at high temperatures, but they are more prone to wear at cold temperatures. The manufacturer, however, does not explicitly consider the drawback posed by the carbon's porosity and moisture absorption, even though this information can be inferred from some of the instructions in the procedures. Both pilots stated they were unaware of the porosity of carbon brakes. The crew, thus, were not actually aware of the dangers and consequences of landing with frozen brakes. The procedures published by the manufacturer and adopted by the operator, however, are consistent with the contents of the EASA's Safety Information Bulletin. There seems to be a need, though, for the information contained in said Bulletin to be disseminated among the personnel involved. As a result, the following safety recommendations are issued:

**REC 73/16** It is recommended that Bombardier explicitly state in its procedures the drawbacks posed by the porosity of carbon brakes, their ability to absorb moisture and the potential for brake assemblies to freeze so as to make this information known to affected personnel.

**REC 74/16** It is recommended that Air Nostrum explicitly include in its training material the drawbacks posed by the porosity of carbon brakes, their ability to absorb moisture and the potential for brake assemblies to freeze so as to make this information known to affected personnel.

The weather conditions at the airport on the day of the incident were similar to those considered in the manufacturer's procedures (Cold Weather Operations and/or Contaminated Runway Operations), as well as in the operator's courses on cold weather operations. The crew should have known these procedures, and stated they were unable to comply due to restrictions at the airport (short taxi distance and mountainous terrain). As a result, the following safety recommendation is issued:

**REC 75/16** It is recommended that Air Nostrum evaluate the characteristics of the Pamplona Airport (LEPP) to ensure it complies with its procedural requirements (Cold Weather Operations and/or Contaminated Runway Operations), and the need to write a special procedure for this airport.

Deficiencies were detected in how the procedures in the Winter Operations Plan were applied, as well as in the specific training given to the personnel (RFFS) involved in both measuring contaminants and clearing the movement area (maneuvering area and apron). After conducting its analysis, the airport reported it would be taking certain actions, but as of this writing, the Commission is unaware of what measures were finally adopted. As a result, two safety recommendations are issued in this regard.

**REC 76/16** It is recommended that the Pamplona Airport (LEPP) take the measures necessary to provide the specific training needed by the RFFS personnel that is involved in both measuring contaminant depth and the coefficient of friction, and in clearing the movement area.

**REC 77/16** It is recommended that the Pamplona Airport (LEPP) revise the procedures in its Winter Operations Plan to specify the tasks involved in measuring contaminants and removing them from the movement area.

## 5. APÉNDICES

APPENDIX A: SAFETY INFORMATION BULLETIN.

APPENDIX B: TRANSCRIPT.

APPENDIX C: VIEW OF THE AIRPORT.





**APPENDIX A**

**SAFETY INFORMATION BULLETIN**



EASA SIB No: 2008-89



## EASA Safety Information Bulletin

**SIB No.:** 2008-89  
**Issued:** 19 December 2008

- Subject:** Tire Failure – Locked Carbon Disc Brake due to Moisture Absorption and Freezing.
- Ref. Publication:** Transport Canada Civil Aviation (TCCA) Service Difficulty Advisory AV-2008-08 dated 2 December 2008.
- Description:** TCCA has published the referenced advisory document (attached as pages 2 and 3 of this bulletin) to inform operators and flight crew of aircraft equipped with carbon disc brakes of the possibility of moisture absorption and subsequent freezing during flight, resulting in tire failure and damage to the aircraft on landing, due to a locked wheel brake.
- After reviewing the available information, EASA concurs with the advisory and fully supports the TCCA recommendations contained therein. This SIB is published to ensure that all owners, operators and maintenance personnel of affected aircraft, registered in European Union Member States or associated countries, are aware of these recommendations.
- Applicability:** All fixed-wing aircraft with carbon disc brakes installed.
- Contact:** For further information contact the Airworthiness Directives, Safety Management & Research Section, Certification Directorate, EASA. E-mail: [ADs@easa.europa.eu](mailto:ADs@easa.europa.eu).

---

This is information only. Recommendations are not mandatory.



Transport Canada / Transports Canada

TP 7394

|      |            |     |
|------|------------|-----|
| No.  |            | 1/2 |
| N°   | AV-2008-08 |     |
| Date | 2008-12-02 |     |

**SERVICE DIFFICULTY  
ADVISORY**

This Service Difficulty Advisory brings to your attention a potential problem. It is a non-mandatory notification and does not preclude issuance of an airworthiness directive.

**TIRE FAILURE - LOCKED CARBON DISC BRAKE  
DUE TO MOISTURE ABSORPTION AND FREEZING**

Reference: SAE Aerospace Information Report AIR4762; Compilation of Freezing Brake Experience and Suggested Designs and Operating Procedures Required to Prevent Its Occurrence

The purpose of this Airworthiness Advisory is to inform Canadian operators and flight crews operating aeroplanes equipped with carbon disc brakes of the possibility of moisture absorption and subsequent freezing during flight, resulting in tire failure and damage to the aeroplane on landing due to a locked wheel brake.

Transport Canada Civil Aviation was advised of an occurrence involving an aeroplane equipped with carbon disc brakes that landed with a locked wheel brake. During the landing rollout on a dry runway, the locked brake caused the associated tire to rupture. As the rollout continued, the wheel became free to rotate, causing the tire to shed and flail large portions which caused significant damage. The tire rupture resulted in the loss of two of three hydraulic systems, damage to the flap structure, and damage to electrical wiring, which controlled multi-function wing spoilers.

Prior to departure, the aeroplane was exposed to a significant amount of rainfall and the carbon disc brakes were soaked with water. The aeroplane taxied with minimal use of braking and took-off under dry conditions about 12 hours after the rain had stopped. Automatic brake application occurred after landing gear retraction. Moisture on the contact faces of the brake froze as the aeroplane climbed to high altitude in sub-freezing conditions.

The braking materials in the stators and rotors of carbon disc brakes are porous which allows them to absorb or retain moisture. After extensive water soaking the brakes can be dried by a prolonged period of exposure to dry warm conditions or deliberate braking action during taxi to heat the brakes. If a wet brake is not heated sufficiently to evaporate moisture from the disk surfaces, there is a possibility that after in-flight cold soak or parking in freezing conditions, the brake surfaces may freeze together. In addition to exposure to environmental moisture, brakes may become soaked with water during washing if the correct procedures to protect the brakes are not followed.

**AVIS DE  
DIFFICULTES EN SERVICE**

Cet avis aux difficultés en service a pour but d'attirer votre attention sur un problème possible. Il est une notification facultative et n'exclut pas nécessairement la publication d'une consigne de navigabilité.

**DÉFAILLANCE DE PNEU – FREIN DE DISQUE EN  
CARBONE BLOQUÉ À CAUSE D'UNE ABSORPTION  
D'HUMIDITÉ SUIVIE D'UN GEL**

Référence : SAE Aerospace Information Report AIR4762; Compilation of Freezing Brake Experience and Suggested Designs and Operating Procedures Required to Prevent Its Occurrence

Le présent Avis de maintien de la navigabilité vise à informer les exploitants et les équipages de conduite canadiens utilisant des avions munis de freins à disque en carbone du risque d'absorption d'humidité et de gel ultérieur en vol pouvant entraîner une défaillance de pneu et des dommages à l'avion à cause d'un frein de roue bloqué.

Transports Canada - Aviation civile a été mis au courant d'un événement mettant en cause un avion de construction canadienne équipé de freins à disque en carbone qui s'est posé alors qu'un frein de roue était bloqué. Pendant la course à l'atterrissage sur piste sèche, le frein bloqué a provoqué une rupture du pneu de cette roue. Alors que la course à l'atterrissage se poursuivait, la roue a finalement pu tourner, et le pneu s'est alors désagrégé en gros morceaux qui sont venus percuter l'avion au point de causer d'importants dommages. La rupture du pneu s'est traduite par la perte de deux des trois circuits hydrauliques, par des dommages à la structure des volets et par des dommages au câblage électrique desservant les déporteurs d'aile multifonctions.

Avant le départ, l'avion avait été exposé à d'importantes chutes de pluie, au point où les freins à disque en carbone avaient fini par être détrempés. Pendant le roulage, l'avion avait fait un usage minimal des freins avant de décoller par temps sec, 12 heures après que la pluie avait cessé. Un freinage automatique avait eu lieu après la rentrée du train d'atterrissage. L'humidité présente sur les surfaces de contact du frein a gelé alors que l'avion montait à haute altitude par des températures négatives.

Les matériaux servant au freinage présents dans les stators et les rotors des freins à disque en carbone sont poreux, et ils peuvent donc absorber ou retenir l'humidité. Une fois détrempés, les freins peuvent sécher s'ils restent exposés à des conditions chaudes et sèches pendant une période de temps prolongée ou si l'équipage freine délibérément pendant le roulage afin de faire chauffer les freins. Si un frein mouillé ne peut chauffer suffisamment pour faire évaporer l'humidité présente sur les surfaces d'un disque, il se peut qu'après une imprégnation par le froid en vol ou un stationnement dans des conditions de gel, les surfaces d'un disque se collent sous l'effet du gel. En plus d'être exposés à l'humidité due à la météo, les freins peuvent aussi être détrempés par l'eau d'un lavage si les bonnes méthodes de protection des freins ne sont pas employées.

To request a change of address, contact the Civil Aviation Communications Centre (AACCC) at Place de Ville, Ottawa, Ontario K1A 0N8, or 1 800 305-2059, or [www.tc.gc.ca/civilaviation/communications/centre/address.asp](http://www.tc.gc.ca/civilaviation/communications/centre/address.asp)

24-0028 (01-2005)

Pour demander un changement d'adresse, veuillez contacter le Centre des communications de l'aviation civile (AACCC) à Place de Ville, Ottawa (Ontario) K1A 0N8, ou 1 800 305-2059, ou [www.tc.gc.ca/aviation/civil/communications/centre/adresse.asp](http://www.tc.gc.ca/aviation/civil/communications/centre/adresse.asp)





|           |            |     |
|-----------|------------|-----|
| No.<br>N° | AV-2008-08 | 2/2 |
|-----------|------------|-----|

In this occurrence the failed tire was of cross-ply construction. Tires of radial-ply construction do not possess the same failure mode and detached debris is likely to be significantly smaller and lighter. However, it is still possible that debris from a radial-ply construction tire failure may damage the aircraft.

- Flight crews and maintenance personnel are reminded that carbon disc brakes can absorb or retain moisture. If a wet brake is not heated sufficiently to evaporate moisture from the disk surfaces, there is a possibility after in-flight cold soak or parking in freezing conditions, the brake disk surfaces may freeze together. Should this occur, taxiing might produce a flat spot on the tire or the tire may burst on landing.
- Maintenance personnel are reminded to protect aircraft wheels and brakes from direct washing spray and inform the flight crew if the aircraft or landing gear has been washed recently.
- In accordance with the AFM and any other manufacturer's documents, if carbon disc brakes have been exposed to moisture, flight crews are reminded to:
- During taxi, use light brake applications to warm the brakes before take off. If equipped, monitor brake temperatures during taxi.
- When landing, carry out a positive landing to ensure initial wheel spin-up and breakout of frozen brakes if frozen brakes are suspected.
- Avoid touch-and-go landings if frozen brakes are suspected.
- During the landing roll and subsequent taxi, use brakes to prevent progressive build-up of ice on the wheels and brakes. If equipped, monitor brake temperatures during taxi.

Following take-off or landing on wet, snow or slush covered runways and taxiways, tires should be inspected for flat spots prior to the next flight.

Caution – The freezing of Carbon disc brakes may occur prior to or following take-off even though conditions prior to take-off are not considered to be cold nor adverse weather operations (Adverse weather conditions include rain, snow or slush or operations on taxiways and runways covered with these contaminants).

For further information contact a Transport Canada Centre, or call Roman Marushko, Certification and Operational Standards 613-993-4692 or [roman.marushko@tc.gc.ca](mailto:roman.marushko@tc.gc.ca)

For Director, Aircraft Certification

Derek Ferguson  
A/Chief, Continuing Airworthiness  
Chef intérimaire, Maintien de la navigabilité aérienne

Dans le présent événement, le pneu défaillant était un pneu diagonal. Les pneus radiaux ne possèdent pas le même mode de défaillance, et les morceaux qui s'en détachent sont généralement beaucoup plus petits et plus légers. Toutefois, il est toujours possible qu'un avion soit endommagé par les débris d'un pneu radial qui se rompt.

- Nous rappelons aux équipages de conduite et au personnel de maintenance que les disques de frein en carbone peuvent absorber ou retenir l'humidité. Si un frein humide n'est pas chauffé suffisamment pour faire évaporer l'humidité sur les surfaces d'un disque, il se peut qu'après une imprégnation par le froid en vol ou un stationnement dans des conditions de gel, les surfaces d'un disque se collent sous l'effet du gel. Si une telle situation se produit, un méplat peut se produire sur le pneu pendant le roulage, ou le pneu risque d'exploser à l'atterrissage.
- Nous rappelons au personnel de maintenance de protéger les roues et les freins d'un avion contre tout jet direct d'eau pendant un lavage et d'informer l'équipage de conduite si l'avion ou le train d'atterrissage vient d'être lavé.
- Conformément à l'AFM et à tout autre document du constructeur, si des freins à disque en carbone ont été exposés à de l'humidité, les équipages de conduite ne devraient pas oublier ce qui suit :
- Pendant le roulage, appuyer légèrement sur les freins pour les faire chauffer avant le décollage. Si l'équipement le permet, surveiller la température des freins pendant le roulage.
- À l'atterrissage, se poser fermement pour forcer les roues à tourner et dégripper des freins gelés, si l'on suppose qu'ils pourraient l'être.
- Éviter les posés-décollés si l'on suppose que les freins pourraient être gelés.
- Pendant la course à l'atterrissage et pendant le roulage subséquent, freiner pour éviter toute accumulation de glace sur les roues et les freins. Si l'équipement le permet, surveiller la température des freins pendant le roulage.

Après un décollage, un atterrissage ou un roulage sur des pistes ou des voies de circulation mouillées, enneigées ou couvertes de neige fondante, mieux vaut toujours s'assurer de l'absence de méplat sur les pneus avant le prochain vol.

Avertissement – Les freins à disque en carbone peuvent geler avant ou après le décollage, même si les conditions avant le décollage ne sont pas considérées comme des opérations par temps froid ou dans de mauvaises conditions météorologiques (ce qui comprend la pluie, la neige ou la neige mouillée, ou l'utilisation de pistes ou de voies de circulation recouvertes de ces contaminants).

Pour de plus amples renseignements, communiquer avec un Centre de Transports Canada ou appeler Roman Marushko, Normes opérationnelles et de certification 613-993-4692 ou [roman.marushko@tc.gc.ca](mailto:roman.marushko@tc.gc.ca)

Pour le directeur, certification des aéronefs

Note: For the electronic version of this document, please consult the following Web address:

Nota: La version électronique de ce document se trouve à l'adresse Web suivante :

[www.tc.gc.ca/CivilAviation/certification/menu.htm](http://www.tc.gc.ca/CivilAviation/certification/menu.htm)



**APPENDIX B**  
**TRANSCRIPT**





Original communications were held in Spanish language. English translation is provided for understanding purposes. In case of doubt, Spanish version prevails.

|                                       |  |
|---------------------------------------|--|
| 05:17:18 (RFFS TELEPHONE)             |  |
| TWR                                   | Yes?   |
| SSEI                                  | Good morning, can you test the alarm?  |
| TWR                                   | Yes.   |
| SSEI                                  | OK, it works.  |
| TWR                                   | How's the runway?  |
| SSEI                                  | Good, there's a little bit of melted snow, when cars pass by they splash everywhere and last night at eleven thirty we sprayed some urea. In any case, I'll inform operations now. |
| TWR                                   | OK, OK. You'll give me the braking efficiency, right?  |
| SSEI                                  | What? I can't hear you well, sorry.  |
| TWR                                   | I was asking if you could give me the braking efficiency and all that.   |
| SSEI                                  | I have to ask Operations and see if we have to go.   |
| TWR                                   | Ok, talk to you soon.  |
| SSEI                                  | Bye.   |
| 05:18:57 (OPERATIONS-CECOA TELEPHONE) |  |
| TWR                                   | Yes?   |
| OPS                                   | The firefighters are telling me the snow is melting, it's like water. The friction car is going to make a run now.   |
| TWR                                   | That's right.  |
| OPS                                   | As soon as they tell me anything I'll let you know.  |
| TWR                                   | OK.  |
| OPS                                   | OK, later.   |
| 05:24:42 (118.2/ LOCAL)               |  |
| SSEI                                  | Pamplona Tower, friction car. Do you copy? Over.   |
| TWR                                   | Friction car, tower, go ahead.   |
| SSEI                                  | I'm letting you know that even though the airport's not operational yet, or if it is, I'm entering the runway to do the friction test.   |
| TWR                                   | Roger, no problem.   |
| SSEI                                  | So I'm clear to enter. I'll report when the runway is clear.   |
| TWR                                   | Roger, cleared to enter the runway and report when runway clear.   |
| 05:31:36                              |  |
| SSEI                                  | Pamplona Tower, friction vehicle, reporting runway is clear. Thanks. Out.  |
| TWR                                   | Runway clear, roger, Thanks.   |
| 05:31:56                              |  |
| ANE8529-                              | Pamplona, good morning from ANE8529  |
| TWR                                   | ANE8529, Pamplona tower, good morning, go ahead.   |
| ANE8529                               | Runway conditions please.  |

## Report IN-005/2015

|                                 |  |
|---------------------------------|--|
| TWR                             | ANE8529, roger, we just took a reading, I'll have the results soon. Wind is three two zero one nine knots gusting to two five, QNH 1006, temperature 2, dewpoint 0, visibility over 10, scattered at two thousand, broken at 4000. What we have for now is melting snow. I'll have the braking efficiency in a minute. |
| ANE8529                         | Copy, 33, 1006 and that's it, waiting on the readings.   |
| TWR                             | Copy, I'll call you right back.  |
| 05:34:00 (OPERATIONS TELEPHONE) |  |
| TWR                             | Yes?   |
| OPS                             | Good morning, let's see, the coefficient of friction is 038.   |
| TWR                             | 038 right? Which translates into...  |
| OPS                             | That's what the firefighters are going to (garbled) now. I don't know if you have it there.  |
| TWR                             | 038 is medium-good.  |
| OPS                             | Medium-good, right?  |
| TWR                             | And are all three segments more or less the same?  |
| OPS                             | Yes, it says 38,38 and in one 39.  |
| TWR                             | So 38 in the first third, 38 in the second and 39 in the third.  |
| OPS                             | 39 yes.  |
| TWR                             | From 33 to 15 I assume.  |
| OPS                             | That's right.  |
| TWR                             | OK, OK. And the runway width, it's all available, right? No snow on the edges...   |
| OPS                             | Well the firefighter (garbled) right now, but he said it was pretty good. Yes, yes, yes.   |
| TWR-                            | OK, so we're operational?  |
| OPS                             | Yes, I'll go get them and as far as the friction, we were operational before the firefighters went out, that's for sure.   |
| TWR                             | Oh, OK, OK.  |
| OPS                             | OK   |
| TWR                             | Aerodrome operational then.  |
| OPS                             | That's right, ok, later.   |
| 05:36:50 (118,2)                |  |
| TWR                             | ANE8529 tower...   |
| ANE8529                         | Go ahead.  |
| TWR                             | Yes, the braking efficiency is medium-good, medium-good, medium-good.  |
| ANE8529                         | OK, copy. Would it be possible to check it again just before our departure, when we're ready to taxi.  |
| TWR                             | Yes, I'll call Operations right now. When do you expect to taxi?   |
| ANE8529                         | I'll let you know, we just started boarding.   |
| TWR                             | Roger..  |
| ANE8529                         | Is there a problem with the flight plan? Because we're supposed to leave at half past, right?  |
| TWR                             | Yes, your EOBT is at 5 30, with that EOBT you can be in the air at 5:50, so... I don't think so, so please modify the flight plan.   |
| ANE8529                         | Great, we'll call back, thanks.  |

|                                 |   |
|---------------------------------|---|
| 05:37:47 (OPERATIONS TELEPHONE) |   |
| OPS                             | Yes?  |
| TWR                             | You heard, right? They want a reading right before they leave.  |
| OPS                             | A reading before they leave. OK, I'll call the firefighters then.   |
| TWR                             | They can stay... They're going to give me an estimated taxi time and when they're ready to taxi, well ready to taxi or 3 or 4... they need 5 minutes more or less, right?   |
| OPS                             | Yes. Yes, yes, yes.   |
| TWR                             | OK, call the firefighters again then.   |
| OPS                             | OK, will do.  |
| TWR                             | OK, bye.  |
| 05:45:30 (118,2)                |   |
| ANE8529                         | Pamplona, ANE8529.  |
| ANE8529                         | Pamplona, ANE8529   |
| TWR                             | ANE8529, yes Pamplona, go ahead.  |
| ANE8529                         | Yes, you plan to clear the snow before we take off, right? ¿  |
| TWR                             | I don't think so. I'll check. No.   |
| 05:46:14 (OPERATIONS TELEPHONE) |   |
| OPS                             | Yes?  |
| TWR                             | Did you hear that?  |
| OPS                             | Yes, I heard, but they don't plan to because it's very soft. It's like water. They say you drive on it in the car and it's like a puddle.   |
| TWR-                            | OK.   |
| OPS                             | I don't know, if they want us to clear it, I suppose I'll have to tell them to clear it.  |
| TWR                             | I have to tell them something. I'll tell them melting snow and if they need it then...  |
| OPS                             | OK, OK, good.   |
| TWR                             | But then they would be delayed...   |
| OPS                             | Yeah, a lot. Yes, yes, yes.   |
| TWR                             | OK wait.  |
| OPS                             | OK.   |
| 05:47:00 (118,2)                |   |
| TWR                             | ANE8529, yes, I'm told that it's melted snow, it melts when you drive over it, but if you need it cleared, then we'll clear it. The only thing is it would delay you quite a bit.   |
| ANE85299                        | OK, then in that case all we need is that before we taxi, while we're deicing, to have the yellow car do a braking test, that's all. Because if it drops to poor, then we're up against a limit there.  |
| TWR                             | ANE8529, yes, copy. The car will need about 5 minutes, plus another to work out the figures... Let me know when you want the car to do its run. Oh, well when you see us starting to deice, when they start to clean the airplane, if you want... Because it's going to be clean, request to taxi and take off. |
| TWR                             | ANE8529, roger, we'll do it like that, then.  |
| ANE8529                         | Thanks  |

## Report IN-005/2015

|                                 |  |
|---------------------------------|--|
| 05:47:56 (OPERATIONS TELEPHONE) |  |
| OPS                             | Yes?   |
| TWR                             | They're going to start deicing, so what they need is for the friction measuring vehicle to make a run because if it falls below medium they wouldn't be able to take off.    |
| OPS                             | OK then, in... I'll tell them to... Though if they take too long... it's really snowing now.   |
| TWR                             | Right  |
| OPS                             | OK   |
| TWR                             | They have to deice, taxi and take off without... or they can't leave. I suppose then that it'll take the vehicle 5 minutes for the check... They're loaded and ready, right? |
| OPS                             | Yes, yes, yes, yes   |
| TWR                             | Five minutes then. Don't delay in converting the readings.   |
| OPS                             | OK, what I'll do... I'll tell them to leave now, right?  |
| TWR                             | In a bit, as soon as they start deicing.   |
| OPS                             | Oh, OK, OK.  |
| TWR                             | If not they won't have time (garbled) the runway. Standing by on frequency 118.2 and as soon as they start deicing I'll clear them to enter the runway.                      |
| OPS                             | OK, good. Talk to you soon.  |
| 05:53:18                        |  |
| TWR                             | Yes?   |
| OPS                             | Hey, it doesn't look like they're going to deice.  |
| TWR                             | They are, it's headed there now... that little truck   |
| OPS                             | Oh right, OK, later.   |
| 05:53:45 (118,2)                |  |
| TWR                             | Friction vehicle, tower...   |
| SSEI                            | Friction vehicle, go ahead.  |
| TWR                             | Friction vehicle, cleared to enter the runway, monitor the frequency and report when runway is clear.  |
| SSEI                            | Did they request the test?   |
| TWR                             | Yes, confirmed, they're starting to deice the airplane now. Proceed.   |
| SSEI                            | Roger, acknowledge cleared to enter runway. I will monitor the frequency and report when runway is clear.  |
| 05:55:23                        |  |
| TWR                             | ANE8529 if you want I can clear you for engine start-up and ATC.   |
| ANE8529                         | Yes, please, we're starting to deice and we see the yellow car starting the test. Thank you.   |
| TWR                             | ANE8529, you are cleared to Madrid Barajas, via NOLSA UNO DELTA, initial flight level nine zero, squawk five zero three six, start-up approved.                              |
| ANE8529                         | Cleared NOLSA UNO DELTA, nine zero, five zero three six for ANE 8529.  |
| TWR                             | ANE8529, ATC correct.  |
| TWR                             | 8529 copy last METAR: visibility 3000, snow, broken at 600, broken 2000  |
| ANE8529                         | Copy, 8529   |
| 06:00:33                        |  |

|                                 |  |
|---------------------------------|--|
| SSEI                            | Pamplona tower, friction vehicle, reporting runway clear.  |
| TWR                             | Copy runway clear, thank you.  |
| 06:06:29 (OPERATIONS TELEPHONE) |  |
| OPS                             | Yes?   |
| TWR                             | How's it going?  |
| OPS                             | Let's see, I'm waiting for him to come up because he tore a piece of paper, but it was 31, 36, and the last one I'm guessing is 36. But I'm missing the last figure. |
| TWR                             | OK   |
| OPS                             | OK, I'll double-check it in a minute. I'll call you back. Oh, I think he's coming. OK, bye.  |
| 06:07:12                        |  |
| OPS                             | (Garbled), let's see 31, 36, 33  |
| TWR                             | OK, that's different. What's that? Uh...   |
| OPS                             | Before I told you it was...  |
| TWR                             | Medium, medium-good, medium.   |
| OPS                             | That's right   |
| TWR                             | OK, so, the first and last third are worse. OK, thanks.  |
| OPS                             | OK, talk to you later.   |
| 06:07:46 (118,2)                |  |
| TWR                             | ANE8529 tower...   |
| ANE8529                         | Go ahead, I was just about to call you to taxi.  |
| TWR                             | ANE8529 braking efficiency medium, medium-good, medium   |
| ANE8529                         | Copy, thanks a lot, ready to taxi ANE8529.   |
| TWR                             | ANE8529 cleared to taxi, backtrack, line up runway 33.   |
| ANE8529                         | Cleared to enter, backtrack and line up 33, 8529   |
| 06:11:55 (118,2)                |  |
| TWR                             | ANE8529 wind three six zero, weight knots, gusts one three, cleared to take off runway 33.   |
| ANE8529                         | Cleared to take off on 33, ANE8529   |
| 06:13:16                        |  |
| ANE8529                         | Rolling, 8529  |
| TWR                             | Roger  |
| 06:15:14                        |  |
| TWR                             | ANE8529 continue climbing to flight level one three zero.  |
| ANE8529                         | Climb one three zero, 8529   |
| TWR                             | ANE8529 Madrid control on 124 875, have a good flight.   |
| ANE8529                         | Two four eight seven five, eight five two nine. Bye bye, have a good day. We'll be back.   |
| TWR                             | You too, until next time.  |
| ANE8529                         | Bye bye.   |
| TWR                             | OK, bye bye.   |
| 06:11:55 (118,2)                |  |



**APPENDIX C**

**VIEW OF THE AIRPORT**







