



Havarikommissionen
Accident Investigation Board Denmark

FINAL REPORT

Serious incident

17-03-2016

involving

ATR42-500

LY-DAT

FOREWORD

This report reflects the opinion of the Danish Accident Investigation Board regarding the circumstances of the occurrence and its causes and consequences.

In accordance with the provisions of the Danish Air Navigation Act and pursuant to Annex 13 of the International Civil Aviation Convention, the safety investigation is of an exclusively technical and operational nature, and its objective is not the assignment of blame or liability.

The safety investigation was carried out without having necessarily used legal evidence procedures and with no other basic aim than preventing future accidents and serious incidents.

Consequently, any use of this report for purposes other than preventing future accidents and serious incidents may lead to erroneous or misleading interpretations.

A reprint with source reference may be published without separate permit.

TABLE OF CONTENTS

SYNOPSIS	6
1 FACTUAL INFORMATION.....	8
1.1 History of the flight.....	8
1.2 Injuries to persons	10
1.3 Damage to aircraft.....	10
1.4 Other damage	10
1.5 Personnel information.....	10
1.5.1 The commander.....	10
1.5.1.1 General.....	10
1.5.1.2 Flying experience.....	10
1.5.2 The first officer	11
1.5.2.1 General.....	11
1.5.2.2 Flying experience.....	11
1.6 Aircraft information	11
1.6.1 General.....	11
1.6.2 Aircraft description	12
1.6.2.1 Aircraft general.....	12
1.6.2.2 Power plants.....	12
1.6.3 Fuel system	15
1.6.3.3 Fuel distribution system.....	15
1.6.3.4 Fuel quantity indication system	16
1.6.3.5 Fuel flow indication.....	18
1.6.4 Maintenance history	18
1.6.4.1 General.....	18
1.6.4.2 Fuel system	19
1.6.4.3 Left engine.....	20
1.6.5 Operations manual (OM)	20
1.6.5.1 Crew roles and task sharing	20
1.6.5.2 Hand position during landing	21
1.7 Meteorological information	22
1.7.1 Reported weather at EKEB & EKBI.....	22
1.7.2 Aerodrome forecast (TAF).....	22
1.7.3 Aviation routine weather report (METAR).....	22
1.7.4 Automatic Terminal Information Service	22
1.7.5 Other observations	23
1.8 Aids to navigation.....	23
1.9 Communication.....	23
1.10 Aerodrome information	23

1.11	Flight recorders	23
1.11.1	Solid State Flight Data Recorder (SSFDR).....	23
1.11.2	Solid State Cockpit Voice Recorder (SSCVR)	24
1.11.3	Other data recorders	24
1.11.4	Relevant recorded data.....	25
1.12	Wreckage and impact information.....	27
1.13	Medical and pathological information	27
1.14	Fire	27
1.15	Survival aspects	27
1.16	Tests and research.....	28
1.16.1	Airframe fuel system investigation.....	28
1.16.2	Investigation of engines	30
1.16.2.1	Left engine S/N PCE-AM0028.....	30
1.16.2.2	Right engine S/N PCE-127059.....	32
1.17	Organization and management information.....	32
1.18	Additional information.....	33
1.18.1	Fuel management	33
1.18.1.1	The technical log.....	33
1.18.1.2	Procedures.....	36
1.19	Useful or effective investigation techniques.....	37
2	ANALYSIS.....	38
2.1	General.....	38
2.2	Right engine flame out after departure	38
2.3	Left engine compressor stall during approach	39
2.4	Flight operation.....	40
3	CONCLUSIONS.....	42
3.1	Findings	42
3.2	Factors.....	43
3.3	Summary	43
4	SAFETY RECOMMENDATIONS	45
4.1	Safety recommendations.....	45
4.2	Preventative safety measures	45
5	APPENDICES	46
5.1	Fuel quantity indication system accuracy	47
5.2	JIC 28-42-72-RAI-10000 revision 07/2015.....	48
5.3	JIC 28-42-00-FUT-10000 revision 07/2015	49
5.4	Troubleshooting manual section 28-21 revision 01/2016.....	50
5.5	Troubleshooting manual section 28-42 revision 01/2016.....	51

5.6	Aerodrome chart EKBI.....	52
5.7	Eng flame out at take off checklist.....	53
5.8	Single eng operation checklist	54
5.9	PWC engine maintenance manual 72-00-04 fault code 39.....	55
5.10	Left engine borescope inspection report	56
5.11	Left engine ECTM data	57
5.12	JIC 28-42-72-RAI-10000 revision 07/2018.....	58
5.13	Troubleshooting manual section 28-21 revision 07/2017	59
5.14	Operators revised OM-B procedure.....	60

FINAL REPORT

General

File number: 2018-101 (Previous file number HCLJ510-2016-300)
UTC date: 17-03-2016
UTC time: 20:44
Occurrence class: Serious incident
Location: Esbjerg (EKEB)
Injury level: None

Aircraft

Aircraft registration: LY-DAT
Aircraft make/model: ATR42-500
Current flight rules: Instrument Flight Rules (IFR)
Operation type: Scheduled
Flight phase: Take-off
Aircraft category: Fixed wing
Last departure point: Esbjerg (EKEB)
Planned destination: Billund (EKBI)
Aircraft damage: None
Engine make/model: Pratt & Whitney Canada PW127E

SYNOPSIS

Notification

All times in this report are UTC.

The Area Control Centre at Copenhagen Airport Kastrup (EKCH) notified the Aviation Unit of the Danish Accident Investigation Board (AIB) of the serious incident on 17-03-2016 at 21:24 hours.

On 18-03-2016, the AIB notified the Danish Transport and Construction Agency (DTCA), the International Civil Aviation Organization (ICAO), the European Aviation Safety Agency (EASA), the Directorate-General for Mobility and Transport (DG MOVE), the French Bureau d'Enquêtes et d'Analyses (BEA), the Transport Accident and Incident Investigation Division at the Ministry of Justice of the Republic of Lithuania (LRTM) and the Canadian Transportation Safety Board (TSB).

The BEA and the TSB appointed accredited non-travelling representatives to the AIB safety investigation.

Summary

Shortly after take off from Esbjerg (EKEB), the right engine flamed out due to fuel starvation.

Despite the fuel quantity indication system indicated more than 500 kg of fuel in the right fuel tank, the right fuel tank was later found to be empty.

During the single engine approach, the left engine suddenly suffered from compressor stall, and flames were seen from the exhaust. The flight crew interpreted the flames as being an engine fire.

Upon landing, the aircraft vacated the runway, the left engine was shut down and the crew evacuated the aircraft.

The safety investigation found that the fault in the fuel quantity indication system originated from the right tank probe no. 3.

Few months prior to the serious incident, maintenance personnel removed and reinstalled the fuel tank probes. The AIB finds it probable that the fault on probe no. 3 was introduced during this process.

The left engine suffered from high deterioration and damages to the hot section. This made the engine subjectable to compressor stall.

The serious incident occurred in dark night and under Instrument Meteorological Conditions (IMC).

The AIB safety investigation resulted in revisions of maintenance and operator procedures.

1 FACTUAL INFORMATION

1.1 History of the flight

The serious incident flight was an IFR domestic flight from EKEB to Billund (EKBI).

The serious incident flight was the third and last flight of a route between Billund (EKBI) – Stavanger (ENZV) – Esbjerg (EKEB) – Billund (EKBI).

Prior to the first flight departing EKBI, the aircraft was refueled with 1,325 kilograms (kg). According to the technical log, the total fuel quantity on board was 2,805 kg.

The flights EKBI - ENZV and ENZV - EKEB were line check flights for the left-hand seated pilot, who underwent commander training. Upon arrival at EKEB, the left-hand seated pilot had passed the line check. For that reason, the left-hand seated pilot acted as commander of the serious incident flight from EKEB to EKBI.

The line check pilot, who supervised the previous line check flights, still occupied the cockpit jump seat on the serious incident flight from EKEB to EKBI.

The commander was the pilot monitoring, and the first officer was the pilot flying.

At 20:44 hours, the aircraft took off from runway 26 at EKEB.

During climb at approximately 560 feet Radio Altitude (RA) the right engine suffered an uncommanded in flight shutdown (flame out).

The Automatic Take-off Power Control System (ATPCS) increased power on the left engine to compensate and started an automatic feathering sequence of the right propeller.

A flight crew power management selection from “TO” to “CLB” interrupted the automatic feathering sequence.

By heart, the flight crew performed the checklist memory items and manually feathered the right propeller.

Established in climb, the flight crew discussed the situation, decided not to declare an emergency and proceeded to EKBI.

The flight crew informed the Aerodrome Flight Information Service (AFIS) at EKEB of the engine failure and the decision to proceed to EKBI.

The flight crew verified that the boxed (memory) items of the “Eng flame out at take off” checklist were performed, but without attempting to restart the engine.

Esbjerg AFIS transferred the aircraft to Billund Approach.

Billund Approach issued radar vectors for the Instrument Landing System (ILS) to runway 27.

The commander briefed the passengers about the emergency and the decision on proceeding to EKBI.

In cruise at 3,000 feet mean sea level, the flight crew attempted to restart the right engine. The attempt was unsuccessful.

Low visibility procedures were in force at EKBI, and the flight crew requested an ILS category I landing for runway 27.

Billund Approach transferred the aircraft to Billund Tower.

On short final to runway 27, the left engine suffered compressor stall and significant torque fluctuations.

The first officer removed his left hand from the left power lever, grabbed the control wheel with both hands and manually disconnected the autopilot without a callout.

The commander perceived that the left engine torque indication had dropped and rapidly moved the left engine power lever forward without any callout.

The cabin crew observed flames from the exhaust and at the rear bottom of the left engine cowling and reported *engine fire* to the flight crew.

When engine compressor stall occurred for the third time, the flight crew witnessed flames themselves.

The commander ordered *brace for impact – emergency landing*.

The flight crew obtained visual contact with the runway, and the aircraft landed on runway 27. The aircraft vacated the runway via taxiway C and came to a full stop on taxiway C. The flight crew requested fire and rescue services.

The flight crew shut down the left engine. On order by the commander, the cabin crew initiated an evacuation of the aircraft.

The flight crew performed the “On ground emer evacuation” checklist, pulled the left engine fire handle and discharged the fire bottles into the engine compartment.

Fire and rescue services arrived at the scene. No fire was present.

1.2 Injuries to persons

<i>Injuries</i>	<i>Crew</i>	<i>Passengers</i>	<i>Others</i>
Fatal			
Serious			
None	6	7	

1.3 Damage to aircraft

There were no damages to the aircraft.

1.4 Other damage

There were no other damages.

1.5 Personnel information

1.5.1 The commander

1.5.1.1 General

The commander (39 years) was the holder of an Airline Transport Pilot License (ATPL) issued by the Civil Aviation Administration, Republic of Lithuania on 18-4-2012.

The rating for ATR 42/72 / IR (A) was valid until 30-4-2017.

The Class 1 Medical Certificate was valid until 21-6-2016.

1.5.1.2 Flying experience

	Commander	First officer	Total
All types (hours)	255:44	2,972:57	3,228:41
This type (hours)	100:26 (supervised)	2,972:57	3,073:23

1.5.2 The first officer

1.5.2.1 General

The first officer (52 years) was the holder of an Airline Transport Pilot License (ATPL) issued by the Civil Aviation Administration, Republic of Lithuania on 30-5-1994.

The rating for ATR 42/72 / IR (A) was valid until 31-5-2016.

The Class 1 Medical Certificate was valid until 5-12-2016.

1.5.2.2 Flying experience

	Commander	First officer	Total
All types (hours)	10,252:47	2,479:00	12,731:47
This type (hours)	5,906:44	1,579:00	7,485:47

1.6 Aircraft information

1.6.1 General

Registration:	LY-DAT
Type:	ATR42
Model:	500
Manufacturer:	ATR - GIE Avions de Transport Régional
Serial number:	445
Year of manufacture:	1994
Engine manufacturer:	Pratt & Whitney Canada Inc. (PWC)
Engine type:	PW127E
Left engine serial number:	PCE-AM0028
Right engine serial number:	PCE-127059
Propellers:	Hamilton Standard, 568F-1
Aircraft time since new:	29,601 Flight Hours (FH)
Aircraft cycles since new:	24,436 Flight Cycles (FC)

Mass and balance:

Aircraft empty mass:	12,229 kg
Maximum take-off mass:	18,600 kg
Actual take-off mass:	13,969 kg
CG limitations:	15 - 34 % MAC (limitation at 13,969 kg)
Actual CG:	22 % MAC

1.6.2 Aircraft description

1.6.2.1 Aircraft general

Subject ATR42-500 was a twin engine turboprop. The cabin was configured with a single corridor in the middle with four passenger seats on each row. Two seats on each side of the corridor, a total of up to 48 passenger seats.

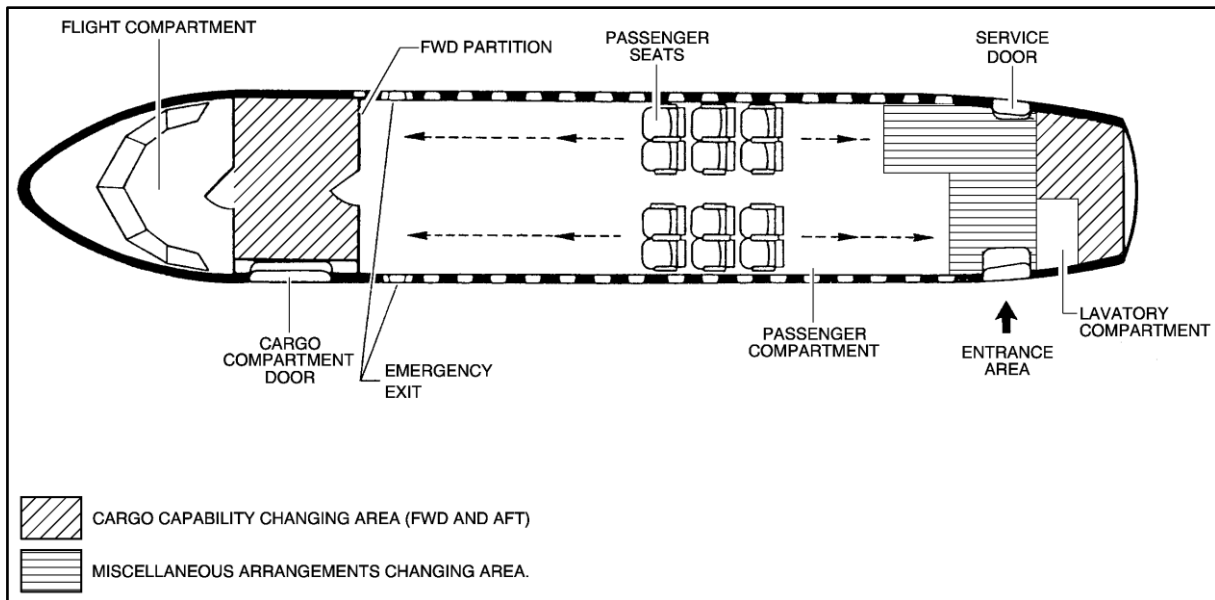

1.6.2.2 Power plants

Subject ATR 42-500 was fitted with two Pratt & Whitney Canada (PWC) PW127E turboprop engines, each rated to deliver a power output of 2,400 shaft horsepower (SHP). Each engine drove a six-bladed variable pitch Hamilton Standard 568F-1 propeller through a reduction gearbox. Both propellers were clockwise rotating and rated at 1,200 revolutions per minute (rpm) corresponding to 100% rotor speed (NP).

The engine had three rotating assemblies:

- A single stage axial Low Pressure Turbine (LPT), drove a single stage radial Low Pressure Compressor (LPC). The rpm of this shaft was expressed as % NL.
- A single stage axial High Pressure Turbine (HPT), drove a single stage radial High Pressure Compressor (HPC). The rpm of this shaft was expressed as % NH.
- A two stage axial power turbine drove the propeller through the reduction gearbox. The rpm from the output of the reduction gearbox on the propeller shaft was expressed as % NP.

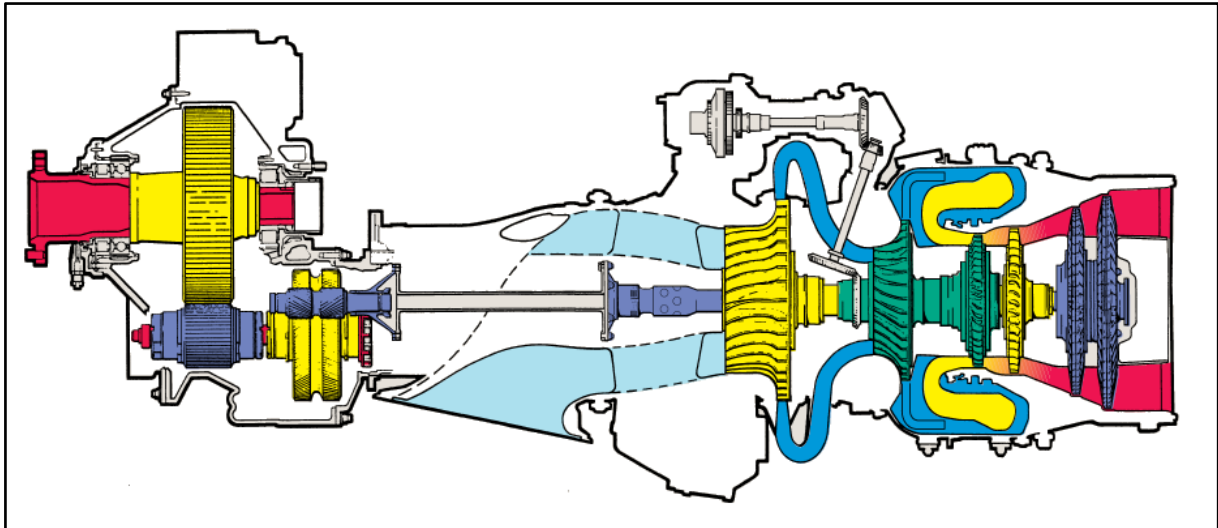

In normal mode, an Engine Electronic Controller (EEC) controlled the fuel flow from the Mechanical Fuel Control Unit (MFCU) to the fuel nozzles. The EEC controlled a stepper motor inside the MFCU to modify the fuel flow and controlled the torque (TQ), in order to match the external conditions and the positions of:

- The Power Lever.
- The Power Management (PWR MGT) Selector Switch.
- The Bleed Valves.

With the power lever at the notch position, the EEC delivered the rated power corresponding to the mode selected by the PWR MGT switch. The PWR MGT switch had the following selectable modes:

PWR MGT Switch position	Propeller RPM (NP)	Torque (TQ)	Max power output (SHP)
TO - Normal Take off	100%	90%	2,160
Reserve Take off	100%	100%	2,400
MCT - Maximum continuous thrust	100%	100%	2,400
CLB - Climb	82%	*	2,160
CRZ1 - Cruise 1	82%	*	2,132
CRZ2 - Cruise 2	77%	*	2,132

*Depending on ambient conditions

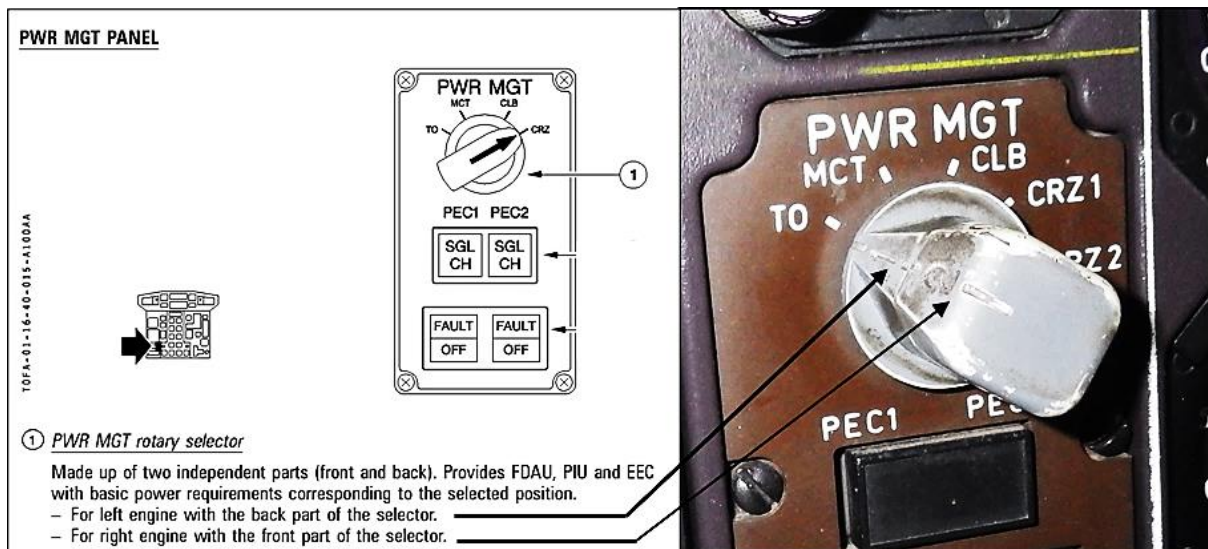

A Propeller Electronic Controller (PEC) controlled the commanded propeller rpm (NP). A Propeller valve module (PVM) would modify the propeller blade angle hydraulically by use of engine oil.

In case of an engine failure during take-off, an Automatic Take off Power Control System (ATPCS) sensed the reducing TQ from the failed engine, and commanded full up-trim Reserve Take Off (RTO) power from the operating engine. A propeller feathering signal was then sent to the failed engine.

The ATPCS system would be disarmed after take-off, when the PWR MGT switch was selected from TO mode to CLB mode.

To avoid compressor stalls, the engine was fitted with an Intercompressor Bleed Valve (IBV). The purpose of the IBV, was to bleed air from between the LPC and the HPC (P2.5) at low rpm conditions to minimize the risk of a compressor stall.

In normal condition, the EEC controlled the IBV through a servo motor. With the EEC in failed/off condition, the IBV was pneumatically self-controlled.

The pneumatic adjustment of the IBV was performed by changing a metering plug orifice to allow the IBV to close at the correct NH setting in case of an EEC failure. The IBV was designed to start closing at 84 % NH and would be fully closed at 91.5 % NH.

The engine maintenance manual hard time maintenance program required engine Hot Section Inspection (HSI) after 4,000 FH, and engine overhaul was required after 8,000 FH. These intervals could be extended by utilizing an engine on-condition maintenance program.

Monitoring of engines parameters was required for engines utilizing the on-condition program. Engine Condition Trend Monitoring (ECTM) was used for this purpose.

The engines on LY-DAT were utilizing the on-condition maintenance program. The left engine had operated 4,975 FH since last overhaul. A HSI had not been performed since the overhaul.

1.6.3 Fuel system

1.6.3.3 Fuel distribution system

The aircraft had two fuel tanks, one in each wing. The volumetric capacity was 2,866 liters corresponding to 2,250 kg in each tank. Aircraft total fuel capacity was 4,500 kg. During normal operation, each wing tank supplied the corresponding engine, but each tank could supply both engines through a crossfeed system.

Inside each tank, on the inboard side between rib 4 and rib 5, was a feeder tank with a capacity of 200 liters corresponding to 160 kg. Each feeder tank contained an electric fuel pump, a motive flow jet pump and a feeder tank jet pump.

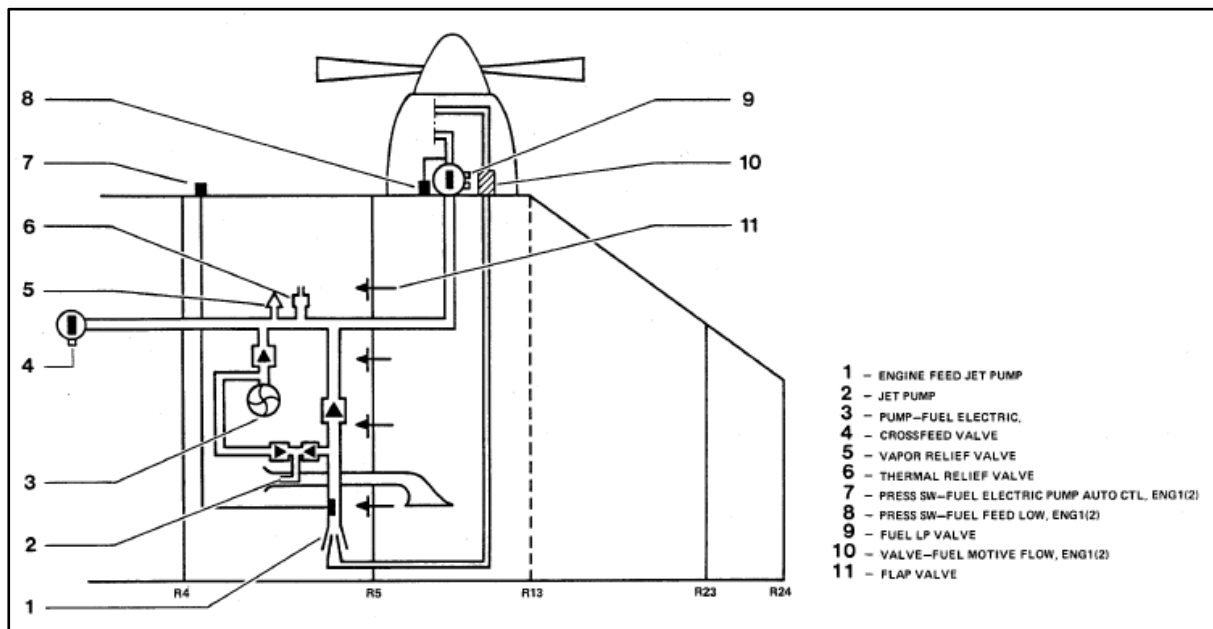

The electrical pump and the motive flow jet pump supplied the engine(s) during startup and operation.

The feeder tank jet pump transferred fuel from the main tank into the feeder tank to ensure the feeder tank was kept full at all time. In case the feeder tank jet pump clogged up or failed, fuel would flow through flap valves into the feeder tank, but the feeder tank would no longer be topped up to full.

1.6.3.4 Fuel quantity indication system

An electrical capacitance type system measured the fuel quantity in the tanks.

The system consisted of five capacitance probes per tank, connected to a Fuel Quantity Indicator (FQI) located in the cockpit. The FQI consisted of two independent channels, one for each tank, which computed the fuel quantity in the tanks based on the capacitance signal from the probes.

The fuel quantity indication from the cockpit was also displayed on a fuel quantity repeater located at the refueling panel below the right wing. The system had an inaccuracy of between 1 and 3 %, up to 60 kg per tank (see [appendix 1](#)). The displayed numbers would be rounded off to the nearest 10 kg.

The FQI had a low level light for each tank. The light illuminated when the total fuel quantity in a tank went below 160 kg. It would be accompanied by a Master Caution (MC) light with single chime and an illumination of the fuel light on the Central Alerting Panel (CAP).

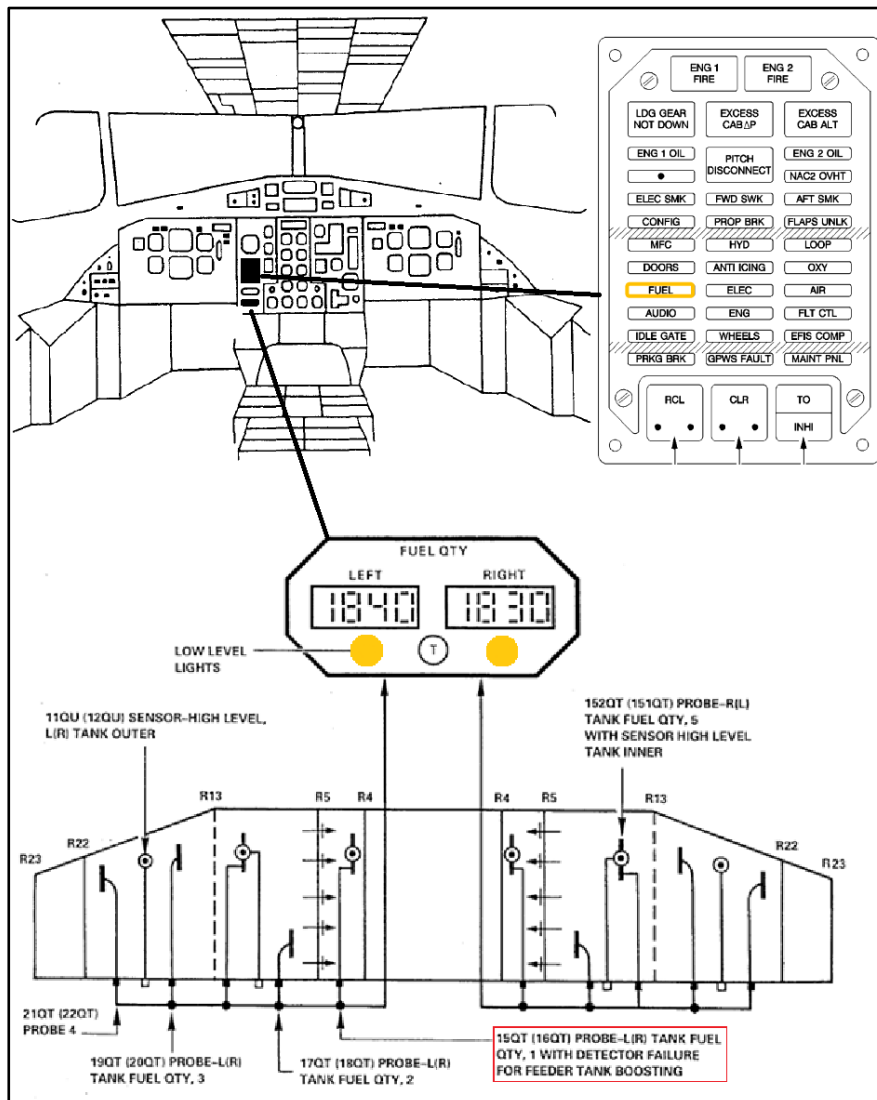

The aircraft manufacturer developed a modification which separated the low level indication system from the fuel quantity indication system. This allowed an independent fuel tank low level indication. The modification could be retrofitted by incorporating Service Bulletin (SB) ATR42-28-0033.

The modification made use of the low level switch already installed onto probe no. 1. This low level switch was used to log a feeder tank jet pump fault in the Multi Function Computer (MFC), when the feeder tank was less than full.

If the modification was incorporated, the low level light would illuminate when the quantity in the feeder tank was below 160 kg, regardless of the total fuel quantity indicated for the fuel tank. The light had a time delay of 10 minutes to avoid nuisance cautions.

At the time of the serious incident, SB ATR-42-28-0033 was not incorporated onto the aircraft.

Two manual magnetic fuel quantity indicators were installed on the lower wing surface of each tank. In the event of a failure of the electrical capacitance system, the fuel quantity on board could be determined by reading the indicated value on the magnetic indicators, and calculating the fuel on board by use of graphs in the Flight Crew Operating Manual (FCOM).

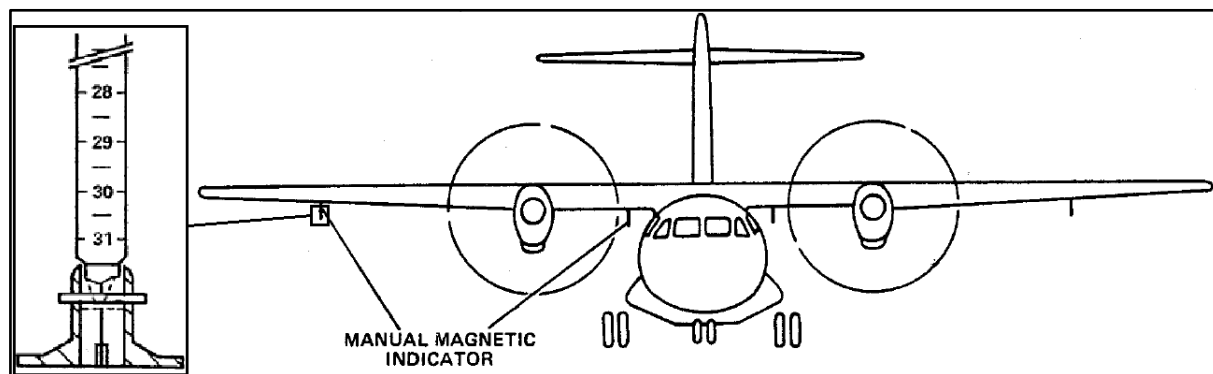

1.6.3.5 Fuel flow indication

Electrical fuel flow transmitters installed on the engines measured the Fuel Flow (FF) to the engine fuel nozzles. The electrical signal from the fuel flow transmitters was transmitted to the fuel flow indicators in the cockpit.

The accumulated Fuel Used (FU) by each engine during flight was displayed at the bottom of the indicator with a resolution of one kg. See below picture of the indicators.

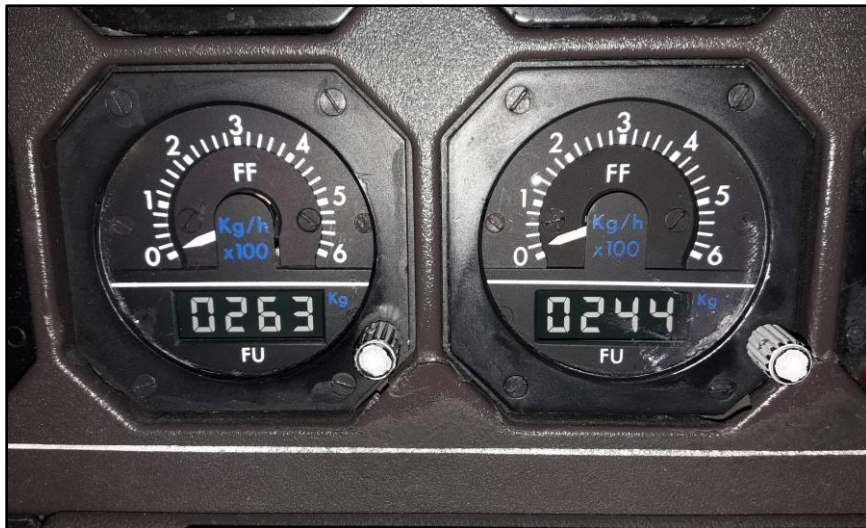

1.6.4 Maintenance history

1.6.4.1 General

From 14-12-2015 until 09-02-2016, the aircraft underwent a heavy maintenance check. Apart from the routine heavy maintenance tasks, the check included replacement of the right engine, defueling of aircraft, fuel tank maintenance and troubleshooting left engine compressor stall.

Upon release from heavy maintenance on 09-02-2016, the aircraft was positioned at EKBI and underwent Airworthiness Review Certificate (ARC) inspection and minor defect rectification.

On 02-03-2016, the aircraft resumed revenue service and completed 75 flights up until the serious incident flight.

All of these flights had a duration of either approximately 10 minutes between EKBI and EKEB, or approximately one hour between ENZV and EKEB/EKBI.

1.6.4.2 Fuel system

During the heavy maintenance check, EASA Airworthiness Directive (AD) 2014-0075 was performed.

The AD mandated the removal of a batch of suspected faulty fuel capacitance probes identified by serial numbers. If maintenance records did not firmly indicate, which serial number probes were installed, a physical inspection of the probe serial numbers was required.

The probes were removed and installed in accordance with the manufacturer's Job Instruction Card (JIC) "28-42-72-RAI-10000-003 Removal and installation of fuel quantity or fuel temp/quantity probe" as described in the AD.

JIC "28-42-72-RAI-10000-003" required a test of fuel quantity indicators after the removal and installation in accordance with JIC "28-42-00-FUT-10000-002 Functional test of fuel quantity indication". See [appendix 2](#).

The test described in JIC "28-42-00-FUT-10000-002" consisted of a total defueling of the aircraft, followed by a refueling where valves and indication lights were checked. Once the tanks were indicated as full, a check of the correlation between the FQI and FQI repeater was required.

At the time of the check, it was not a clear requirement from JIC "28-42-00-FUT-10000-002" to verify that the loaded fuel quantity corresponded to the fuel quantity indicated on the FQI. See [appendix 3](#).

The installed probes were not affected by the AD, and none were replaced during the check.

On 14-03-2016 the flight crew reported in the technical log *FUEL on CAP but no local alerts. 1 time on take off and 2 times during cruise.*

The defect was signed off with replacement of right engine fuel filters.

On 16-03-2016 the flight crew reported in the technical log *FUEL on CAP multiple times during last flight- no local alert. Caution disappears when right fuel pump is off.*

The defect was transferred to the deferred defect list and the aircraft was released by use of the Minimum Equipment List (MEL). The used MEL reference was "28-21-2 electrical fuel pump fault", a category C item allowing a maximum of 10 days in service.

At the time of the serious incident, the Troubleshooting Manual (TSM) did not describe a procedure for illumination of the FUEL light on CAP with no local alert associated. See [appendix 4](#).

The TSM only described a troubleshooting procedure for FUEL light on CAP with associated low level light on the FQI when quantity was displayed as low. See [appendix 5](#).

1.6.4.3 Left engine



Defects found during the heavy maintenance check included left engine compressor stalls during engine performance check. The IBV and metering plug orifice were replaced, and the defect card was signed off with fault no longer present on the following engine performance check.

1.6.5 Operations manual (OM)

The text below are extracts from the operators OM-B:

1.6.5.1 Crew roles and task sharing

- *Both pilots have to crosscheck and confirm aircraft configuration changes*
- *Airspeed bugs settings*
- *Transfer of control of the aircraft*
- *Any changes to autopilot, heading, altitude or mode selection on AFCS/ADU*
- *Altimeter settings*
- *Clearances*
- *Mass and balance calculations and associated GNSS entries*
- *Performance calculations*
- *GPS/GNSS setup and changes*
- *Radio navigation aids during critical phases of flight*
- *EFB Data (if applicable)*

<i>Pilot flying PF</i>		<i>Mutual monitoring and support</i>		<i>Pilot not flying PM</i>
<ul style="list-style-type: none"> - Aircraft control - Power control - Flight path and airspeed control - Aircraft configuration - Navigation - Call for checklists 		<ul style="list-style-type: none"> - Condition levers positioning - Checklist reading - Execution of relevant actions - Systems management and monitoring - Radio communications 		
<i>Pilot in command</i>	<i>Non-transferable roles</i>		<i>First officer</i>	
<ul style="list-style-type: none"> - Leadership - Long term planning - Final decision - PF – PM role assignment 	<ul style="list-style-type: none"> - Decision support - Suggestions 			

1.6.5.2 Hand position during landing

Power levers

Pilot flying must put his hand on the PL's at any time during flight when leaving or capturing an altitude, and when altitude is below 2500 FT AGL. During landing, below minima, Pilot monitoring must place one hand behind the PL's just over the IDLE GATE, so he/she is ready to take control of the aircraft or pull the idle gate upon touchdown if this does not auto extend.

Control wheel

Whenever the autopilot is off, and/or when below 2500 FT AGL, the pilot flying must have one hand on the control wheel – this also applies when autopilot is on. Pilot flying must put his hand on the controls at any time during flight when more than light turbulence or wake turbulence is anticipated.

1.7 Meteorological information

1.7.1 Reported weather at EKEB & EKBI

Reported weather at EKEB by Esbjerg AFIS to the flight crew at 20:31 hours.

Wind 280° and 11 knots. Visibility 3000 meters in mist. Broken clouds at 200 feet. Temperature 4°. Dewpoint 2°. QNH 1022.

Reported weather at EKBI by Esbjerg AFIS to the flight crew at 20:31 hours.

Wind 280° and 11 knots. Visibility 800 meters in fog. Runway Visual Range (RVR) touch down 1500 meters. RVR stop end 1100 meters. Vertical visibility 200 feet. Temperature 4°. Dewpoint 4°. QNH 1022.

1.7.2 Aerodrome forecast (TAF)

TAF amd ekbi 171925z 1719/1818 27010kt 3000 br bkn003 tempo 1719/1801 0500 bcfg bkn001
becmg 1801/1803 34008kt 8000 nsw bkn015 tempo 1803/1808 1200 bcfg bkn001=

TAF ekbi 171725z 1718/1818 27010kt 3000 br bkn003 tempo 1718/1801 1200 bcfg bkn001
becmg 1801/1803 34008kt 8000 nsw bkn015 tempo 1803/1808 1200 bcfg bkn001=

1.7.3 Aviation routine weather report (METAR)

METAR ekbi 172150z 29008kt 0600 r09/1100n r27/1100n fg ovc001 04/04 q1021=

METAR ekbi 172120z 28009kt 0600 r09/1200d r27/1100n fg ovc001 04/04 q1021=

1.7.4 Automatic Terminal Information Service (ATIS)

This is Billund airport information G 2046. Expect radar vectors for ILS approach. Runway in use 27. Runway damped. Transition level 40. Low visibility procedures in operation. Wind 290 degrees 8 knots. Visibility 800 meters. RVR touchdown zone 1200 meters. Midpoint 1200 meters. Stop end 1200 meters. Fog. Overcast 100 feet. Temperature 4. Dewpoint 4. QNH 1021. This was Billund airport information G.

1.7.5 Other observations

During approach, Billund Tower informed the flight crew that the previously landed aircraft reported the approach lights in sight at an altitude of 200 feet above ground level.

1.8 Aids to navigation

The ILS / DME runway 26 at EKEB was operative, and no deficiencies were reported.

The ILS / DME runway 27 (CAT I + II + III) at EKBI was operative and no deficiencies were reported.

1.9 Communication

The flight crew communicated with:

- Esbjerg AFIS on 120.150 MHz
- Billund Approach on 127.575 MHz
- Billund Tower on 119.000 MHz

The AIB recovered the ATC audio recordings. The recordings were of good quality and useful to the AIB safety investigation.

1.10 Aerodrome information

At the time of the serious incident, runway 27 at EKBI was in use.

The commander decided to vacate runway 27 via taxiway C, and the aircraft stopped on taxiway C.

See [appendix 6](#).

1.11 Flight recorders

1.11.1 Solid State Flight Data Recorder (SSFDR)

Manufacturer: L-3 Aviation Communications
Part Number: 2100-4043-00
Serial Number: 000600674

The AIB recovered the SSFDR data. The SSFDR data was of good quality and was useful to the AIB safety investigation.

The SSFDR neither recorded the engine fuel flow, the engine NL, the propeller blade angle, the position of the PWR MGT switch, the position of the bleed air switch, the fuel quantity or the position of the condition levers, nor was it designed to do so.

1.11.2 Solid State Cockpit Voice Recorder (SSCVR)

Manufacturer: L-3 Aviation Communications
Part Number: 2100-1020-02
Serial Number: 000341835

The AIB recovered the SSCVR data. The SSCVR data was of good quality and was useful to the AIB safety investigation.

The majority of the flight crew conversation was in their native language Lithuanian. LRTM assisted on producing an English transcription.

1.11.3 Other data recorders

The Aircraft was equipped with a Multi Purpose Computer (MPC). The MPC stored flight data and transferred the data to the SSFDR. Furthermore, it stored a variety of automatically generated reports (including failures) from the airframe and engine systems.

The flight failure reports from the MPC showed a history of low level fuel float faults. Low level fuel float fault was logged when the fuel quantity in the feeder tank was below 160 kg for 10 minutes, indicating that the feeder tank jet pump was unable to transfer sufficient fuel into the feeder tank.

This was normally due to a clogged or failed feeder jet pump, but could also be an indication of a fuel tank being close to empty. These faults would have been accompanied by FUEL light on CAP and MC to alert the flight crew.

In the period from 03-03-2016 until 17-03-2016, the fault log history showed left low level float faults on 17 occasions.

In the period from 14-03-2016 until 17-03-2016, the right low level float fault had appeared on 19 occasions.

No left nor right low level float faults were present in the reports generated prior to the heavy maintenance check.

1.11.4 Relevant recorded data

The recovered data was used to produce a chronology of key events. All times are UTC (hh:mm:ss).

Time	Event
20:35:47	Startup of engines. Right engine start button pushed. Recording begins. Right NH above 45 % after 10 seconds.
20:44:34	Take off. Weight off wheels. Both engines running at take off power (90 % TQ, 100 % NP).
20:44:49	Right engine loss of power. Right engine TQ drops rapidly followed by a decrease of NH, NP and ITT. Altitude approximately 560' RA.
20:44:51	ATPCS system engages. Left engine TQ increased from 90 % to 100 %. Right engine autofeather sequence initiated. NP decreased.
20:44:57	PWR MGT switch selected from TO to CLB then MCT. Left engine NP and TQ started decreasing, then 5 seconds later increased back to 100 %. Right engine NP stopped decreasing and started to increase (autofeather sequence interrupted). Right engine was still operating at very low power.
20:45:11	Right engine power lever selected to flight idle, then condition lever to shutoff. The flight crew performed the "Eng flame out at take off" checklist memory items.
20:45:49	Flight crew discussed whether to declare an emergency or not. Line check pilot: <i>Say mayday mayday.</i> First officer: <i>No, no. Not mayday, wait.</i> Commander: <i>Don't need mayday.</i>
20:45:53	Flight crew notified EKEB about the flame out and the decision to proceed to EKBI.
20:46:21	"Eng flame out at takeoff" checklist partially performed. Both engine bleed air switches were selected to off. Only the boxed (memory) items were confirmed. There was no attempt to restart the engine at this stage. See appendix 7 .

- 20:50:13 **Passenger briefing.**
After several requests from the cabin crew, the flight crew briefed the passengers about the problem. Up until then the flight crew had been busy with checklists and communication.
- 20:52:44 **After TO checklist completed.**
- 20:52:50 **Flight crew discussed the possibility of restarting the right engine.**
- 20:53:21 **Flight crew performed the “single engine operation” checklist.**
See [appendix 8](#).
- 20:54:12 **Flight crew discussion.**
Flight crew discussed the weather at EKBI and alternative airports.
Flight crew decided to attempt a restart of the right engine, and consulted the “Eng restart in flight” checklist.
- 20:55:37 **Right engine restart attempt.**
Right engine NH & ITT increased. NH stabilized at idle speed.
Right condition lever moved to auto. NP increased and stabilized at 100 %.
Right power lever moved forward for approximately 15 seconds. NH decreased back to 0 % and engine delivered no TQ (flame out).
- 20:56:44 **Right condition lever selected to feather/shutoff.**
- 20:58:28 **Crew performed “single engine operation” checklist again.**
See [appendix 8](#).
- 21:02:24 **“Approach” checklist completed.**
- 21:04:41 **“Before landing” checklist completed.**
- 21:05:03 **First left engine compressor stall.**
Compressor stall audible from CVR. Left TQ fluctuated from stabilized 55 % down to 35 % then up to 75 % within 4 seconds.
First officer manually disconnected the autopilot when the TQ dropped.

- 21:05:10 **Second left engine compressor stall.**
Compressor stall audible from CVR. Left TQ fluctuated from 74 % down to 35 % then up to 55 % within 5 seconds.
The left power lever was advanced in response to the compressor stalls and TQ drop, and TQ increased to 100 %.
Following stabilization, the left power lever was retarded to the previous position.
Cabin crew reported a fire from the left engine.
- 21:05:36 **Third left engine compressor stall.**
Compressor stall audible from CVR. Left TQ drops from 76 % to 25 %.
Left power lever was advanced. TQ increased to 116 %.
Left power lever was then retarded to flight idle.
Flight crew observed flames from the left engine.
- 21:06:05 **Touchdown**
- 21:06:52 **Left engine shutdown**
Flight crew informed tower about possible left engine fire and requested fire brigade.
The crew evacuated the aircraft.
Flight crew performed the “On ground emer evacuation” checklist and discharged both fire extinguishers into the left engine compartment.
Then selected power off.

1.12 Wreckage and impact information

Not applicable.

1.13 Medical and pathological information

Not applicable.

1.14 Fire

The technical investigation showed neither traces of a left engine fire, nor traces of fire in any other part of the aircraft.

1.15 Survival aspects

Not applicable.

1.16 Tests and research

1.16.1 Airframe fuel system investigation.

The initial investigation of the airframe fuel system revealed that:

1. The right fuel tank was physically empty.
2. The FQI in the cockpit and the refuel panel FQI repeater indicated:
 - a. Left fuel tank quantity 410 kg, which corresponded to the amount of fuel in the tank.
 - b. Right fuel tank quantity 510 kg, despite the fuel tank being empty.
 - c. Right fuel tank low level light (LO LVL) did not illuminate on the fuel quantity indicator, despite the physical fuel quantity being below 160 kg (the light will only illuminate when SB-ATR42-28-0033 has been incorporated).



A “functional test of fuel quantity probe system” was performed in accordance with the aircraft manufacturer’s JIC “28-42-72-FUT-10000-002”.

The test was performed by measuring the capacitance of each probe through connectors in the wing root. The test was performed in dry condition, with the probes not immersed in fuel.

The values were compared to the limitations described in the JIC. The results of the test is shown in the table below:

Probe no.	Right tank probes part and serial numbers (PN / SN)	Limitation picoFarad (pF)	pF Value left tank	pF Value right tank
1	798-038 / 702	6.4 +/- 0.8	6.7	6.6
2	766-046-2 / 642	13.22 +/- 0.5	13.4	13.3
3	766-047-2 / 692	36.5 +/- 0.5	36.9	40.2
4	766-048-2 / 667	17.3 +/- 0.5	17.6	18.0
5	768-055 / 675	28.1 +/- 0.5	29.5	28.6
Total		100.2-105	105.2	115.5

The right tank probe no. 3 pF value was out of the limitation described in the JIC, and the total capacitance of the right tank system was also significantly out of limit.

During sequential refueling of the aircraft 200 kg at a time, the erroneous right fuel tank quantity indication remained. During the fuel uplift sequence, the left fuel tank quantity indication displayed correctly.

The right fuel tank probe no. 3 was uninstalled from the right fuel tank and placed on the aircraft wing. A capacitance test was performed with the aircraft harness connected to the probe.

The test revealed that the pF value fluctuated between 40.2 and 47.5 when the brown wire (covered by black heat-shrinkable tubing) was manipulated close to the connector and housing. See picture below.

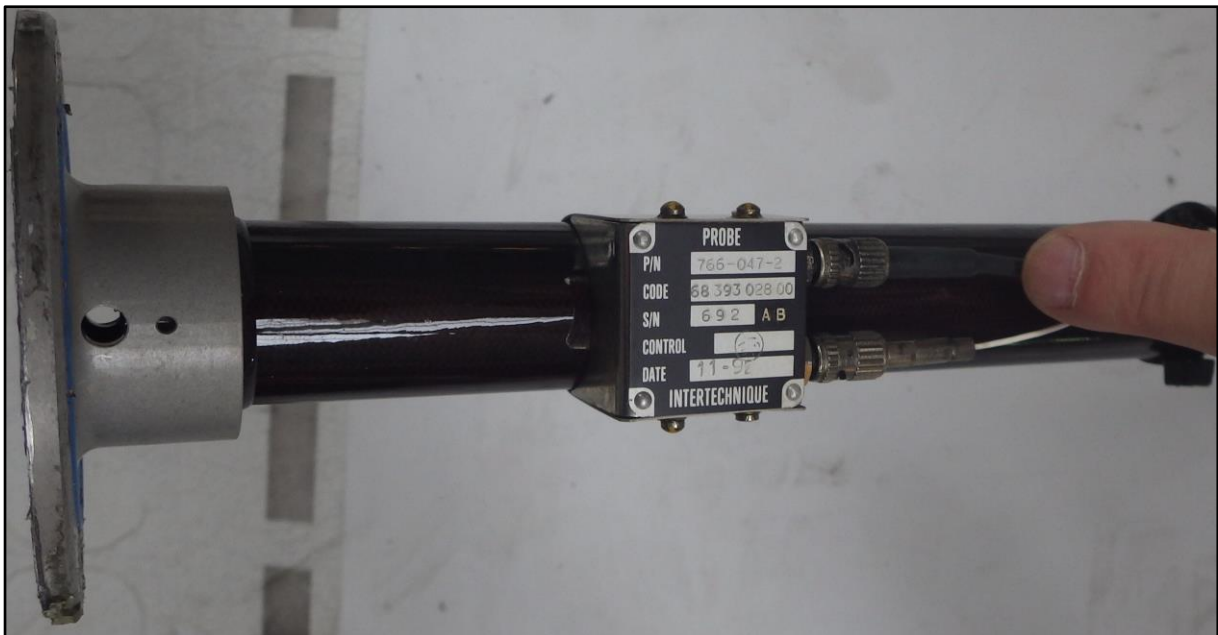

After further manipulation of the wire, the capacitance value of the probe returned to 36.7 pF which was within the limitation of the JIC. It was not possible to replicate the fault, and the faulty connector was replaced.

To confirm that only the connector had failed, an x-ray inspection was performed on the housing and connectors. The inspection revealed no faults within the housing or connections.

The probe and harness were sent to the Original Equipment Manufacturer (OEM), who performed a full test on the probe and harness. The test did not reveal any additional faults within the probe or harness.

1.16.2 Investigation of engines

1.16.2.1 Left engine S/N PCE-AM0028

A visual inspection of the engine was carried out. No defects were found externally on the engine. The engine showed no indication of a fire having taken place.

The EEC memory was checked for fault codes. Multiple codes were present. However only code 39 was related to compressor stall.

Troubleshooting was performed in accordance with “PWC engine maintenance manual chapter 72-00-04”. See [appendix 9](#).

Fault code 39 - Inter-compressor bleed valve (IBV) wraparound interface:

- The fault in the EEC came from a range check performed in the output wraparound circuitry.
- The IBV and harness continuity was checked. No faults were found.
- The final recommendation was to replace the EEC.

The EEC was replaced as part of troubleshooting. This did not resolve the problem with the compressor stall.

The engine surge scenario from the final approach of the flight was simulated by performing JIC “72-00-00-ERU-10050-001 Check of acceleration time of the engine”.

The check was executed with the bleed air system switched off as described in the JIC. During final approach of the serious incident flight, the bleed air was selected off in accordance with the “Eng flame out at take off” and “Single engine operation” checklist. See [appendix 7](#) and [appendix 8](#).

When the acceleration check was performed with the bleed air system switched on it was not possible to provoke an engine compressor stall.

The engine suffered compressor stall, when the power lever was moved quickly forward with bleed air selected off.

To exclude engine related parts, the following parts were replaced as part of troubleshooting:

EEC	P/N: 820154-1-002
MFCU (HMU)	P/N: 3244871-8
Propeller valve module (PVM)	P/N: C146440-2
Propeller electronic control	P/N: 816332-5-401
IBV	P/N: 3071774-01
High pressure bleed valve	P/N: 3214958-2
P2,5 P3 air pressure valve	P/N: 3114892-01
Low pressure check valve new	P/N: CT60-3
Duct air intake	P/N: S5411265600200
Engine air intake boot	P/N: S5411275900001
Bleed air duct seals	P/N: RA50A54
Oil cooler air intake	P/N: S5411267001300
Metering plug orifices	Various P/Ns
Fuel nozzle set	Various P/Ns

The replacement of parts did not resolve the engine compressor stall problem.

To eliminate the airframe systems, the engines were interchanged. This did not resolve the compressor stall problem with the subject engine either. Compressor stall was still experienced on engine S/N PCE-AM0028 during acceleration test with bleed air selected off.

The engine was removed, and a full borescope inspection of the engine was performed. The borescope inspection of the engine revealed significant hot section deterioration. Damages on the HPT blades were out of limitations, and required engine repair. See [appendix 10](#).

Deterioration and damages to the hot section reduced the efficiency of the turbines and caused a reduced speed of the rotors.

The engine running time since last overhaul was almost 5000 FH, and no HSI or repair had been carried out since the overhaul.

An analysis of the engine performance run sheets by the engine manufacturer determined that the rotor speeds and the relationship between NH and NL rotor speeds was very low. This made the engine subjectable to compressor stall.

This was confirmed by a review of the ECTM data. The data showed that the NH had decreased by 3 % over a period of two years due to hot section deterioration. See [appendix 11](#).

1.16.2.2 Right engine S/N PCE-127059

The engine was externally visually inspected without findings.

An internal borescope inspection of the engine revealed no significant defects.

The fuel pump and the gearbox drive train to the HP turbine was checked without findings.

The engine operated as intended during the ground test running.

The cause of the right engine flame out was found to be fuel starvation caused by the empty right fuel tank.

1.17 Organization and management information

The operator provided scheduled services as well as passenger charter and cargo services.

The aircraft fleet consisted of a number of ATR42/72 and Saab 340A twin-engine turboprop aircraft and an Airbus A320 medium-haul jet aircraft.

On 4-3-2010, the Civil Aviation Administration (CAA) of Lithuania issued the certificate of registration for LY-DAT.

On 29-10-2014, the CAA of Lithuania issued an Air Operator Certificate (AOC).

According to the AOC Operations Specifications Specific Approvals issued by the CAA of Lithuania on 25-02-2016, the aircraft was approved for CAT I and II operations.

Approach and landing:

- CAT I: Runway Visual Range (RVR) 550 meters and Decision Height (DH) 200 feet
- CAT II: RVR 300 meters and DH 100 feet

The AOC held an approved Operations Manual (OM) system containing operational documentation and limitations, and Standard Operating Procedures (SOP).

1.18 Additional information

1.18.1 Fuel management

1.18.1.1 The technical log

The technical log pages from the flights leading up to the serious incident were recovered and analyzed.

The basic layout for the calculations in the technical log had the following appearance (numbers inserted as an example):

1000		FUEL		
RAMP	USED	REMAI- NING	PLAN UPLIFT	ACT UPLIFT
1500	195	1300	500	498

TOP LEFT CORNER: Fuel remaining from previous technical log page.
This was not the position where the number was intended to be placed, but the cell was commonly used for this purpose.

RAMP: Fuel quantity before flight.
Displayed on the fuel quantity indicator.

USED: Fuel quantity used during flight.
Displayed on the engine fuel flow indicators.

REMAINING: Fuel remaining after flight.
Displayed on the fuel quantity indicator.

PLAN UPLIFT: Intended fuel uplift to obtain ramp fuel required for flight.

ACT UPLIFT: Fuel quantity uplifted
Calculated based on the fuel receipt.

In the time between the maintenance check release 02-03-2016 until the serious incident on 17-03-2016, four different commanders performed the fuel calculations.

The fuel calculations in the technical log pages were performed in two different ways.

Two commanders did not use the PLAN UPLIFT cell. They only inserted the actual uplift quantity, which would then allow a calculation of the RAMP fuel.

The fuel used numbers were rounded off to nearest 10 kg (or in some cases 50 or 100 kg).

The remaining fuel would always end up being a result of the ramp fuel less the used fuel.

This indicated that the USED number was derived from the fuel quantity indicator and not from the fuel flow meters as intended. Approximately half the technical log pages were filled out this way. See example below.

1100		FUEL		
RAMP	USED	REMAI-NING	PLAN UPLIFT	ACT UPLIFT
2811	161	2650		1711
2650	750	1900		
1900	700	1200		
1200	200	1000		

The other two commanders performed the fuel calculations by planning the fuel uplift, and entering fuel used numbers that were not rounded off.

In these cases, the ACTUAL UPLIFT would not necessarily match the PLAN UPLIFT, and the USED would not necessarily match the RAMP less REMAINING.

This provided an opportunity to spot abnormalities in the fuel quantity indication system. The AIB safety investigation revealed five technical log pages with significant abnormalities:

1. On the technical log page containing the first flights after maintenance on 02-03-2016, there was a significant difference between PLAN UPLIFT and ACT UPLIFT of 476 kg.

The second flight revealed a difference in USED fuel of 94 kg compared to the difference in RAMP versus REMAINING.

1600		FUEL		
RAMP	USED	REMAI-NING	PLAN UPLIFT	ACT UPLIFT
3000	249	2760	1400	1876
2760	726	1940		
1940	704	1310		
1310	141	1100		

2. On the technical log page for 14-03-2016, a difference of 130 kg between PLAN UPLIFT and ACT UPLIFT was present.

The flight crew reported *FUEL on CAP but no local alerts. 1 time on take off and 2 times during cruise* as a technical remark.

1430		FUEL		
RAMP	USED	REMAI- NING	PLAN UPLIFT	ACT UPLIFT
2820	153	2610	1390	1260
2610	776	1860		
1860	660	1260		
1140	222	890		

3. On the first technical log page for 15-03-2016, a difference of 177 kg between PLAN UPLIFT and ACT UPLIFT was present.

On the third flight, the difference between USED fuel compared to RAMP versus REMAINING was 109 kg.

890		FUEL		
RAMP	USED	REMAI- NING	PLAN UPLIFT	ACT UPLIFT
2820	145	2600	1930	1753
2600	687	1980		
1980	651	1220		
1220	153	1010		

4. On the first technical log page for 16-03-2016, a difference of 211 kg between PLAN UPLIFT and ACT UPLIFT was present.

On the third flight, the difference between fuel USED compared to RAMP versus REMAINING was 88 kg.

The flight crew reported *FUEL on CAP multiple times during last flight - no local alert. Caution disappears when right fuel pump is off* as a technical remark.

1150		FUEL		
RAMP	USED	REMAI-NING	PLAN UPLIFT	ACT UPLIFT
2830	192	2600	1680	1469
2600	664	1910		
1930	652	1190		
1190	145	1020		

5. On the first technical log page for 17-03-2016, the first uplift presented a difference of 144 kg between PLAN UPLIFT and ACTUAL UPLIFT and on the second uplift a difference of 98 kg was present.

1600		FUEL		
RAMP	USED	REMAI-NING	PLAN UPLIFT	ACT UPLIFT
2830	201	2600	1230	1086
2600	770	1810		
2400	665	1760	590	492
1760	247	1480		

None of the technical log pages prior to the heavy maintenance check showed significant abnormalities.

1.18.1.2 Procedures

At the time of the serious incident, the operator did not have procedures on how to manage fuel calculations.

At the time of the serious incident, the operator did not have fuel quantity inaccuracy limitations requiring manual checks of fuel quantity.

The aircraft manufacturer described an inaccuracy of 1-3 % of the fuel quantity indication system in the Aircraft Maintenance Manual/Description Operation chapter 28 (fuel).

The aircraft FCOM provided a graph that indicated a maximum inaccuracy of the fuel system of 60 kg per tank. The inaccuracy varied depending on the fuel quantity in the tank. See [appendix 1](#).

1.19 Useful or effective investigation techniques

Not applicable.

2 ANALYSIS

2.1 General

The licenses and the qualifications held by the flight crew, the aircraft mass and balance and the aids to navigation had no influence on the sequence of events.

2.2 Right engine flame out after departure

Shortly after take off from runway 26 at EKEB, the right engine suffered a flame out due to fuel starvation caused by an empty right fuel tank.

The empty right fuel tank was caused by a malfunction in the right part of the fuel quantity indication system.

The malfunction resulted in an incorrectly indicated fuel quantity, which was higher than the actual physical fuel quantity in the right fuel tank. The malfunction was traced to a faulty connector on the right tank probe no. 3.

It is probable that the connector fault was introduced during the heavy maintenance check between 14-12-2015 and 09-02-2016, when the system was last disturbed during performance of AD 2014-0075.

The technical log pages and the MPC reports showed no evidence of problems prior to the heavy maintenance check.

No malfunction in the fuel quantity indication system was revealed during the maintenance check.

At the time of the maintenance check, the test required by the JIC after removal and installation of fuel quantity probes, did not clearly stipulate a requirement for maintenance crew to verify that the uplifted physical fuel quantity corresponded to the indicated fuel quantity.

During operation of the aircraft, the faulty fuel quantity indication remained unrevealed.

The fuel management performed by the flight crews showed significant variations in the fuel calculations.

At the time of the serious incident, the operator did not have procedures on how to manage fuel calculations.

At the time of the serious incident, the operator did not have fuel quantity inaccuracy limitations requiring manual checks of fuel quantity.

Had such procedure been in place, the fuel numbers from the technical log pages would have required a manual check of the fuel quantity by use of magnetic fuel quantity indicators. This would most likely have revealed the faulty FQI system.

Two occasions of fuel caution on CAP were reported in the technical log. The MPC reports indicated that the cautions appeared on other flights as well.

On 14-03-2016, when the fault was first reported in the technical log, the engine fuel filters were replaced.

When reported on the second time on 16-03-2016, the right electrical fuel pump was deemed unserviceable, and the aircraft was MEL released for further flights.

At the time of the serious incident, the TSM did not describe a procedure for illumination of the FUEL light on CAP without associated local alert.

The TSM only described a troubleshooting procedure for FUEL light on CAP with associated low level light on the FQI.

Incorporation of SB ATR-42-28-0033 at the time of the serious incident would have allowed to easier identify the fault in the fuel indication system, by illuminating the low level light on the fuel quantity indicator in relation to the fuel cautions.

2.3 Left engine compressor stall during approach

During the single engine approach to EKBI, the left engine suffered three unprovoked compressor stall events. The compressor stall events resulted in flames from the exhaust, which the crew interpreted as being an engine fire.

The compressor stall would only occur when the left engine was running in bleed air off configuration.

The “Engine flame out at take off” and “Single engine operation” checklists required bleed air to be selected off on the engine in operation. Following the right engine flame out, the flight crew performed these checklist items.

The left engine had suffered compressor stall on a previous occasion.

The maintenance records showed that a compressor stall defect had been raised and corrected during the heavy maintenance check. The defect had been rectified by replacement of the IBV and metering plug orifice, and the left engine had been successfully tested on ground.

Even though the compressor stall problem may no longer have been present at the heavy maintenance check, the deterioration of the engine hot section and the NH and NL rotor speed ratio would still make the engine subjectable to compressor stall.

The problem with the ratio between engine NH and NL rotors was only discovered when the engine manufacturer analyzed the performance run data following the serious incident. The ECTM data confirmed the problem.

Contacting the engine manufacturer was part of the fault isolation procedure described in the engine maintenance manual for compressor stall troubleshooting. In case the fault was not rectified, this would be a last step.

Since the left engine was successfully tested after replacement of the IBV, the engine manufacturer was not contacted during the heavy maintenance check.

2.4 Flight operation

The safety investigation of the serious incident revealed operational deficiencies.

The management of fuel calculations in the technical logbook was less than adequate.

Operator procedures were not in place to ensure that fuel calculations could determine flaws in the fuel quantity indication system, and ensure that sufficient fuel would be on board the aircraft to complete the flights.

Following the right engine flame out, the flight crew decided not to declare an emergency (mayday) to ATC. This was despite the “Eng flame out at take off” being an emergency checklist, and the suggestion to declare an emergency from the line check pilot.

An emergency declaration to ATC could have allowed prioritized airspace, a dedicated radio channel and rescue services on standby. This would have reduced the disturbances and the flight crew workload, which remained high and stressful during the flight.

When the flight crew performed “Eng flame out at take off” checklist, only the boxed (memory) items were performed. See [appendix 7](#). The flight crew did not consider restarting the engine at this stage.

This resulted in the “Single engine operation” checklist being performed prior to the “Eng restart in flight”, and then again following the unsuccessful attempted engine restart. This increased the flight crew workload unnecessarily.

10 minutes after the flame out the flight crew attempted to restart the right engine. This was prompted by a discussion over the cause of the engine failure, and not as a checklist item.

The restart attempt was performed in accordance with the “Eng restart in flight” checklist. The restart attempt was unsuccessful due to the empty fuel tank.

When the left engine compressor stalled during final approach, the first officer removed his left hand from the power levers and disconnected the autopilot without any callout.

The commander took control of the power levers without any callout.

The flight crew did not know that engine compressor stall was the reason for the loud bangs and the flames reported by the cabin crew and witnessed by themselves.

The uncertainty led the flight crew upon landing to discharge both engine fire extinguisher bottles.

This was in accordance with the “on ground emer evacuation” checklist, and was a fair decision given the circumstances.

The flight crew workload was extraordinary high on short final to runway 27 at EKBI because of:

- Poor weather.
- Single engine operation.
- Engine compressor stalls and loss of engine power.
- Flames from the exhaust.

The extraordinary high flight crew workload most likely caused a lack of flight crew call outs and deviation from standard operating procedures for power lever controls.

3 CONCLUSIONS

3.1 Findings

1. The aircraft was certified in accordance with regulations and approved procedures at the time of the serious incident.
2. The flight crew were licensed and qualified for the flight in accordance with the regulations at the time of the serious incident.
3. The right engine suffered an uncommanded in flight shutdown (flame out) at take off due to fuel starvation.
4. Following the right engine flame out, the flight crew decided not to declare an emergency (mayday) to ATC. This was despite the “Eng flame out at take off” being an emergency checklist, and the suggestion of the line check pilot.
5. The right fuel tank becoming empty during flight caused the fuel starvation.
6. The fuel quantity indication system was found to indicate a higher quantity in the right tank, than the fuel quantity actually physically present.
7. A connector on the right tank capacitance probe no. 3 was found to be the cause of the incorrectly displayed fuel quantity from the right tank.
8. The defect on the capacitance probe connector was most likely introduced during removal and installation of the probe at the heavy maintenance check performed between 14-12-2015 and 09-02-2016.
9. At the time of performance of the heavy maintenance check, it was not a clear requirement in the aircraft manufacturer’s job instruction card, to perform a verification of the accuracy of the fuel quantity indication system following removal and installation of a capacitance probe.
10. At the time of the serious incident, the operator did not have procedures on how to manage fuel calculations.
11. At the time of the serious incident, the operator did not have fuel quantity inaccuracy limitations requiring manual checks of fuel quantity.

12. At the time of the serious incident, the TSM did not describe a procedure for illumination of the FUEL light on CAP without associated local alert.
13. The left engine suffered three unprovoked compressor stall events during approach leading to intermittent loss of power from the left engine.
14. The compressor stall was the cause of flames from the left exhaust, leading the flight crew to believe that the left engine had caught fire.
15. Deterioration and damages to the left engine hot section reduced the efficiency of the turbines and caused a reduced speed of the rotors. This made the engine subjectable to compressor stall.
16. During the first compressor stall event, the FO manually disconnected the autopilot, without any callout, and flew the remaining approach manually.
17. At the same time, the commander took power control and compensated for the TQ drop without any callout.

3.2 Factors

1. At the time of performance of the heavy maintenance check, it was not a clear requirement in the aircraft manufacturer's job instruction card, to perform a verification of the accuracy of the fuel quantity indication system after removal and installation of a capacitance probe.
2. At the time of the serious incident, the TSM did not describe a procedure for illumination of the FUEL light on CAP without associated local alert.
3. At the time of the serious incident, the operator did not have procedures on how to manage fuel calculations.
4. At the time of the serious incident, the operator did not have fuel quantity inaccuracy limitations requiring manual checks of fuel quantity.

3.3 Summary

Shortly after take off from Esbjerg (EKEB), the right engine flamed out due to fuel starvation.

Despite the fuel quantity indication system indicated more than 500 kg of fuel in the right tank, the right fuel tank was later found to be empty.

During the single engine approach, the left engine suddenly suffered from compressor stall, and flames were seen from the exhaust. The flight crew interpreted the flames as being an engine fire.

Upon landing, the aircraft vacated the runway, the left engine was shut down, and the crew evacuated the aircraft.

The safety investigation found that the fault in the fuel quantity indication system originated from the right tank probe no. 3.

Few months prior to the serious incident, maintenance personnel removed and reinstalled the fuel tank probes. The AIB finds it probable that the fault on probe no. 3 was introduced during this process.

The left engine suffered from high deterioration and damages to the hot section. This made the engine subjectable to compressor stall.

The AIB safety investigation resulted in revisions of maintenance and operator procedures.

4 SAFETY RECOMMENDATIONS

4.1 Safety recommendations

No safety recommendations were issued.

However, the AIB safety investigation prompted preventative safety measures from the aircraft manufacturer and the operator. See chapter 4.2.

4.2 Preventative safety measures

The aircraft manufacturer revised the following maintenance documents:

- Aircraft Maintenance Manual Job Instruction Card (AMMJIC) “28-42-72-RAI-10000 Removal and installation of fuel quantity or fuel temp/quantity probe”. See [appendix 12](#).
- “Troubleshooting Manual (TSM) chapter 28” (fuel). See [appendix 13](#).

The aircraft manufacturer communicated the importance of proper fuel management to all operators of the aircraft type during a safety conference, and provided guidance material on how to manage fuel.

The operator revised the OM-B with established procedures on how to manage fuel based on the guidance material from the aircraft manufacturer. See [appendix 14](#).

- 5.1 Fuel quantity indication system accuracy
- 5.2 JIC 28-42-72-RAI-10000 revision 07/2015
- 5.3 JIC 28-42-00-FUT-10000 revision 07/2015
- 5.4 Troubleshooting manual section 28-21 revision 01/2016
- 5.5 Troubleshooting manual section 28-42 revision 01/2016
- 5.6 Aerodrome chart EKBI
- 5.7 Eng flame out at take off checklist
- 5.8 Single eng operation checklist
- 5.9 PWC maintenance manual 72-00-04 fault code 39
- 5.10 Left engine borescope inspection report
- 5.11 Left engine ECTM data
- 5.12 JIC 28-42-72-RAI-10000 revision 07/2018
- 5.13 Troubleshooting manual section 28-21 revision 07/2017
- 5.14 Operators revised OM-B procedure

5.1 Fuel quantity indication system accuracy

Return to [fuel quantity indication system](#).

Return to [fuel management procedures](#).

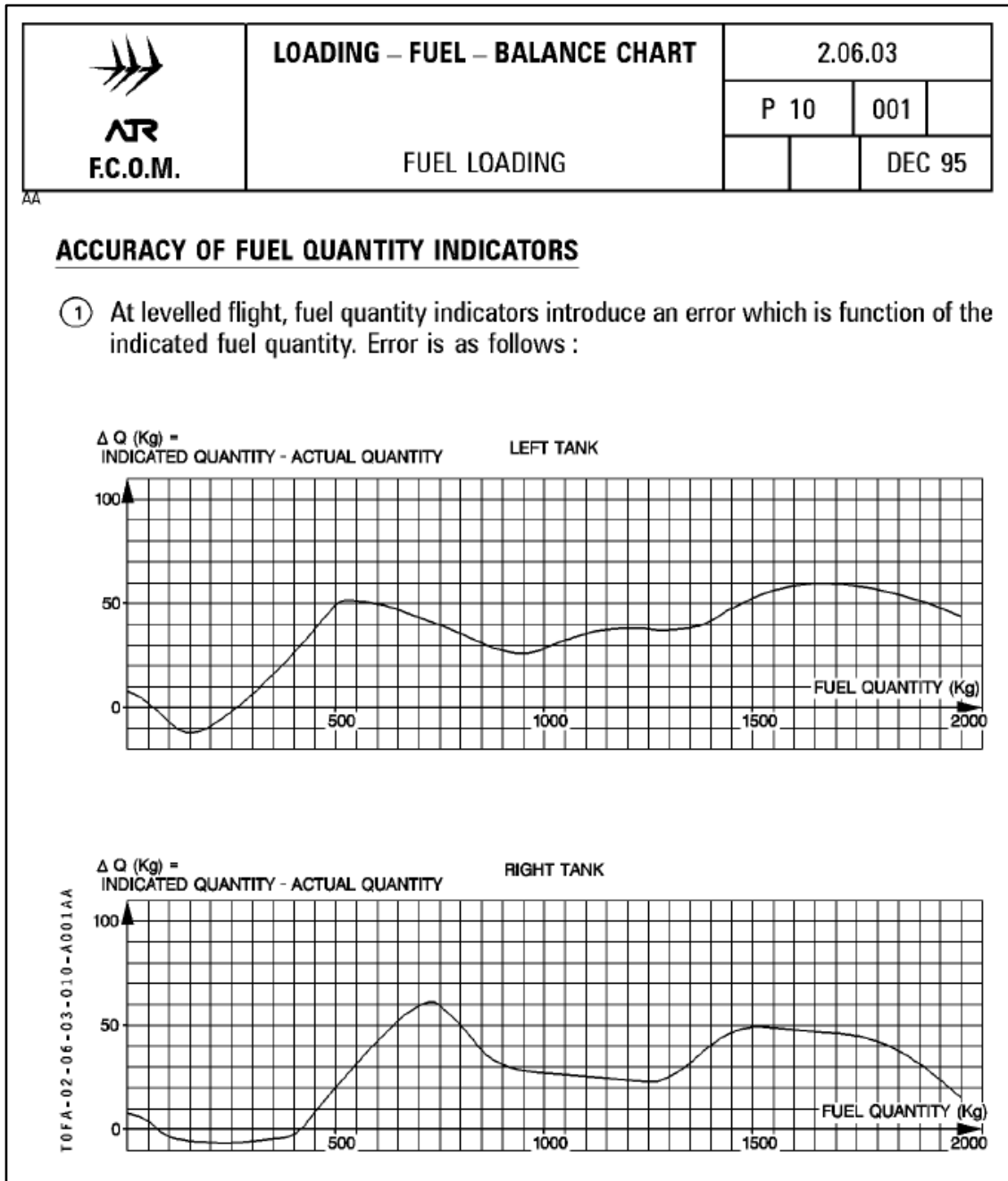

5.2 JIC 28-42-72-RAI-10000 revision 07/2015

Return to [fuel system](#).

	JOB CARD	MPD-TASK :
	R6 - ATR42-500	AMMJIC TASK : 28-42-72-RAI-10000
A/C Reg.: LY-DAT	TITLE: JIC 28-42-72 RAI 10000 : REMOVAL AND INSTALLATION OF FUEL QUANTITY OR FUEL TEMP/QUANTITY PROBE	

7. CONNECT PLUG(S) ON CONNECTOR(S) (2).
REF. FIG. :284272-RAI-00130 ;

8. ALIGN FUEL WIRING (1) ON PROBE
(FORMING A COIL) AND ATTACH IT,
- FIRST IN THE LOWEST POSITION USING
CORRESPONDING TYRAP (2)
- THEN ON MID PROBE HEIGHT USING
CORRESPONDING TYRAP (3).

9. SLOWLY INTRODUCE PROBE ON TANK AND FIX THE
THIRD TYRAP (4) ON PROBE IN HIGHEST
POSITION PLACING THE WIRE IN A U
FORM IN ORDER TO ADJUST THE WIRE LENGTH.
THIS IS IN ORDER TO AVOID A POTENTIAL RISK
OF CHAFING BETWEEN WIRE AND FUEL LINE.
REF. FIG. :
REF. FIG. :284272-RAI-00100

10. PLACE IMMERSED SECTION OF PROBE IN CLEAN
FUEL.

11. INSTALL FUEL QUANTITY PROBE.

12. INSTALL SCREWS (4) AND TIGHTEN.

007 TEST OF FUEL QUANTITY INDICATORS : READING OF FUEL QUANTITY INDICATORS.

EFF : 501-501	Page 8 of 11 DATABASE REV DATE : Jul 01/15 PRINT DATE : Dec 08/15 Local Time
---------------	--

	JOB CARD	MPD-TASK :
	R6 - ATR42-500	AMMJIC TASK : 28-42-72-RAI-10000
A/C Reg.: LY-DAT	TITLE: JIC 28-42-72 RAI 10000 : REMOVAL AND INSTALLATION OF FUEL QUANTITY OR FUEL TEMP/QUANTITY PROBE	

SEE JOB INSTRUCTION CARD
JIC : 284200-FUT-10000

008 CLOSE-UP

1. DISCONNECT AIRCRAFT FROM TANKER.
(IF IT HAS BEEN INSTALLED).

2. REMOVE "SMOKING PROHIBITED" WARNING NOTICES.

3. REMOVE EXPLOSIMETER.

4. REMOVE WARNING NOTICE PROHIBITING ENERGIZA-
TION OF FUEL SYSTEM FROM FLIGHT COMPARTMENT.

5. CHECK THAT WORKING AREA IS CLEAN AND CLEAR
OF TOOLS AND MISCELLANEOUS ITEMS OF EQUIP-
MENT.

6. REMOVE PLATFORM.
(Ref Fig. 28-42-72 WIRE INSTALLATION ON PROBES)

 28-42-72

5.3 JIC 28-42-00-FUT-10000 revision 07/2015

Return to [fuel system](#).

005	<p><u>FUNCTIONAL TEST OF FUEL QUANTITY INDICATOR</u></p> <p>REF. FIG. 282573-FUT-00120</p> <p>1. ON PANEL 121VU</p> <p>. CHECK THAT THE FOLLOWING CIRCUIT BREAKERS ARE CLOSED :</p> <ul style="list-style-type: none"> - 1QT (2QT) FUEL/FQ1/NORM PWR SUPPLY/L (R) TANK - 2QU FUEL/FUELLING/CTL & IND <p>2. ON REFUELING PANEL 5004VU</p> <p>A. PLACE "REFUEL/OFF/DEFUEL" SWITCH (4QU) IN POSITION :</p> <ul style="list-style-type: none"> - REFUEL. <p>B. PLACE "REFUEL VALVE/LH (RH)" SWITCH 5QU (6QU) IN POSITION :</p> <ul style="list-style-type: none"> - NORM (REFUEL/DEFUEL VALVES OPEN) . <p>C. WHEN FUEL PRESSURE FROM TANKER IS NORMAL (3.5 BARS MAX), THE "VALVE/OPEN/LH (RH)" OF ACTUATING INDICATOR LIGHT, COMES ON. FULL TANK TO 2250 KG (4960 LBS) . CHECK OF THIS SAME VALUE IS DISPLAYED :</p> <ul style="list-style-type: none"> .ON FUEL QUANTITY INDICATOR "LEFT"(RIGHT) ON PANEL 4VU. .ON FUEL REPEATER INDICATOR "LEFT"(RIGHT) (IF IT IS PROVIDED) ON PANEL 5004VU. <p>D. ON PANEL 5004VU:</p> <ul style="list-style-type: none"> - PLACE "REFUEL VALVES/LH(RH)" SWITCH IN "SHUT" POSITION. SHUT DOWN PRESSURE <p style="text-align: right;">*** CONTINUED ***</p>			
-----	--	--	--	--

EFFECTIVITY : R6

28-42-00

FUT 10000-002
2-400 PAGE 3
JUL 01/15

Printed in France



ATR42-400/500 SERIES - AMM - Job Instruction Cards

TITLE		28-42-00 FUT 10000-002			
FUNCTIONAL TEST OF FUEL QUANTITY INDICATION		STS.	CHECK	PAGE	DATE
				4	JUL15
ITEM	TASK DESCRIPTION	MECH.	INSP.		
006	<p>FROM TANKER.</p> <p>3. EXECUTE THE SAME CHECK (2.) ON THE OTHER TANK.</p> <p>WHEN THE BOTH INDICATORS ARE CHECKED, PLACE "REFUEL/OFF/DEFUEL" SWITCH ON "OFF" POSITION</p> <ul style="list-style-type: none"> - "VALVE/LH (RH)/OPEN" INDICATOR LIGHTS GO OFF. - PLACE "REFUEL VALVES/LH (RH)" SWITCHES IN "NORM" POSITION. <p><u>REFUELING</u></p>				

5.4 Troubleshooting manual section 28-21 revision 01/2016

Return to [fuel system](#).

FAULT SYMPTOM	FAULT ISOLATION
<ul style="list-style-type: none">On panel 25VU, on FUEL/ENGL(2) caution light 7QA(8QA), FEED LO PR legend is illuminated.	Fig. 101
<ul style="list-style-type: none">On maintenance panel 702VU, FUEL/L(R) FEEDER TANK magnetic indicator 153QA(152QA) shows amber.	Fig. 102
<ul style="list-style-type: none">On panel 25VU, on FUEL/ENGL(2) PUMP P/BSW 11QA(12QA), RUN legend remains illuminated after engine starting without additional warning.	Fig. 103

Engine Feed System

IL2821001A01003-00

R EFFECTIVITY: 005-006,

R6

FAULT SYMPTOMS

28-21

Page 2
Jan 01/16

Printed in France

5.5 Troubleshooting manual section 28-42 revision 01/2016

Return to [fuel system](#).

FAULT SYMPTOM	FAULT ISOLATION
<ul style="list-style-type: none"> On panel 4VU, the fuel quantity displayed on the Fuel Quantity Indicator 3QT is fluctuating or decreasing too quickly. 	Fig. 101
<ul style="list-style-type: none"> On panel 4VU, on Fuel Quantity Indicator 3QT, LO LVL caution light is illuminated, with the fuel quantity indicated on 3QT <160Kg and with fuel level known as "obviously" above the critical level. 	Fig. 103
<ul style="list-style-type: none"> On panels 4VU and 5004VU, the Fuel Quantity Indicator 3QT and the Fuel Quantity Repeater Indicator 6QT do not display. 	Fig. 104
<ul style="list-style-type: none"> On panel 4VU, the Fuel Quantity Indicator 3QT does not display. 	Fig. 105
<ul style="list-style-type: none"> On panel 5004VU, the Fuel Quantity Repeater Indicator 6QT does not display. 	Fig. 106
<ul style="list-style-type: none"> On panel 5004VU, after action on REFUELING FQI TEST pushbutton switch 4QT, the displays do not show all "8": <ol style="list-style-type: none"> On the Fuel Quantity Indicator 3QT and on the Fuel Quantity Repeater Indicator 6QT. 	Fig. 107
<ol style="list-style-type: none"> On the Fuel Quantity Repeater Indicator 6QT. 	Fig. 108
<ol style="list-style-type: none"> On the Fuel Quantity Indicator 3QT. 	Fig. 109
<ul style="list-style-type: none"> On panel 4VU, on Fuel Quantity Indicator 3QT, erratic and very instable fluctuations of the fuel quantity displayed. The information displayed remains in the range of ±10% of the quantity gauged. 	Fig. 110

Quantity Indicating

IL2842001A01002-03

R EFFECTIVITY: ALL

R6

FAULT SYMPTOMS

28-42

Page 1
Jan 01/16

Printed in France

5.6 Aerodrome chart EKBI

Return to [aerodrome information](#).

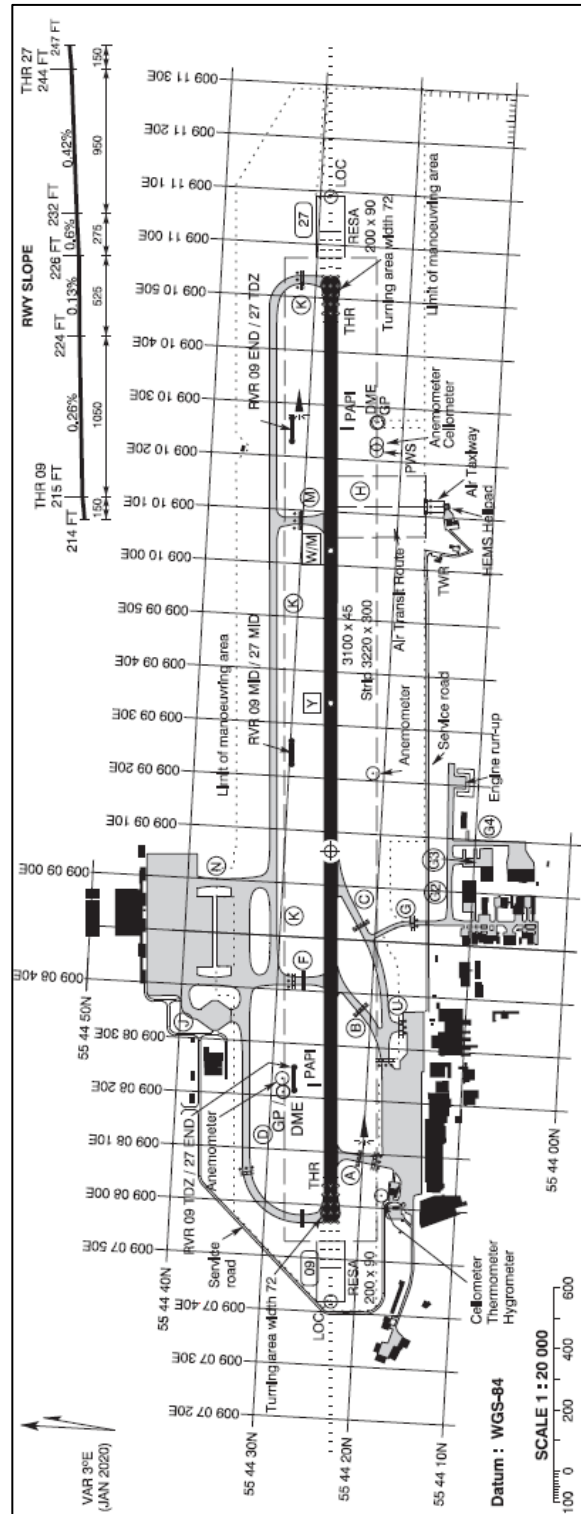

5.7 Eng flame out at take off checklist

Return to [relevant recorded data](#).

Return to [engine investigation](#).

Return to [flight operation](#).

ENG FLAME OUT AT TAKE OFF	
UPTRIM	CHECK
AUTOFEATHER	CHECK
■ If no UPTRIM	
PL 1 + 2	ADVANCE TO THE RAMP
● When airborne	
LDG GEAR	UP
BLEED 1 + 2	OFF, IF NOT FAULT
● At Acceleration Altitude	
ALT	SET
● At VFTO	
PL 1 + 2	IN THE NOTCH
PWR MGT	MCT
IAS	SET
■ If normal condition	
FLAPS	0°
■ If icing condition	
FLAPS	MAINTAIN 15°
PL affected side	FI
CL affected side	FTR THEN FUEL SO
BLEED engine alive	OFF if necessary
■ If damage suspected	
FIRE HANDLE affected side	PULL
LAND ASAP	
SINGLE ENG OPERATION procedure (2.04)	APPLY
■ If no damage suspected	
ENG RESTART IN FLIGHT procedure (2.08)	APPLY
■ If unsuccessful	
LAND ASAP	
SINGLE ENG OPERATION procedure (2.04)	APPLY

5.8 Single eng operation checklist

Return to [relevant recorded data](#).

Return to [engines investigation](#).

SINGLE ENG OPERATION

LAND ASAP

PWR MGT TO if necessary then MCT
FUEL PUMP affected side OFF
DC GEN affected side OFF
ACW GEN affected side OFF
PACK affected side OFF
BLEED affected side OFF
APM (if installed) OFF
TCAS (if installed) TA ONLY
OIL PRESSURE ON FAILED ENGINE MONITOR

Note: In icing conditions, FLAPS 15 will be selected to improve drift down performances and single engine ceiling.

Note: Refer to pages (4.61) and (4.62) to determine single engine gross ceiling.

Note: If during the flight, a positive oil pressure has been noted on the failed engine for a noticeable period of time, maintenance must be informed.

Note: monitor fuel balance. Recommended operational maximum fuel unbalance is 200 kg (440 lb).

● **When FUEL CROSS FEED is required**

FUEL PUMP affected side ON
FUEL X FEED ON
FUEL PUMP operating engine OFF

● **For approach**

MAX APPROACH SLOPE for Steep Slope Approach 5.5°
BLEED NOT AFFECTED OFF
CL live engine 100% OVRD
APPROACH SPEED NOT LESS THAN 1.1VMCA

Note: Refer to page (4.64) to determine 1.1VMCA.

Note: At touch down, do not reduce below FI before nose wheel is on the ground.

5.11 Left engine ECTM data

Return to [left engine S/N PCE-AM0028](#)

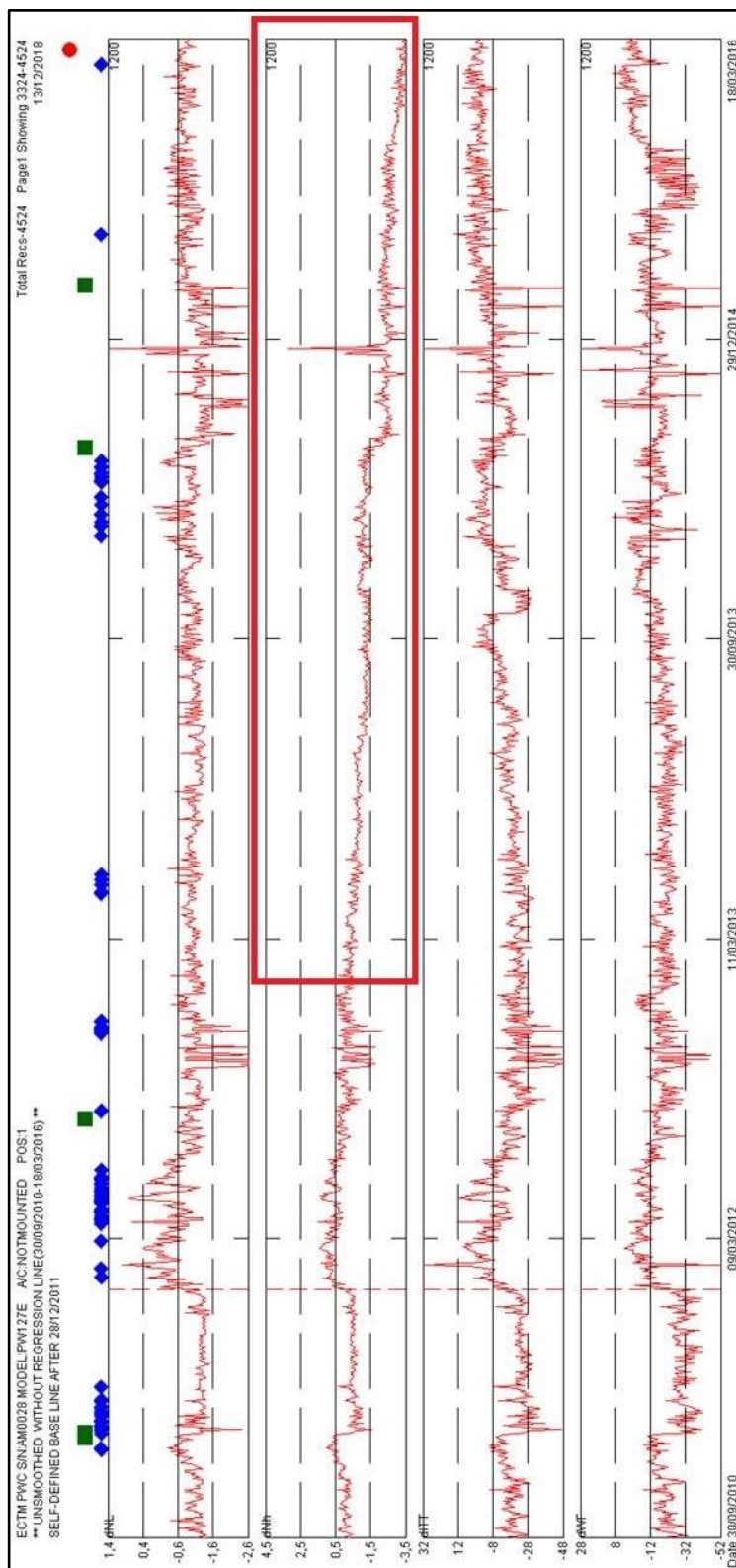

5.12 JIC 28-42-72-RAI-10000 revision 07/2018

Return to [preventative safety measures](#).

007	<p>11. INSTALL FUEL QUANTITY PROBE. 12. INSTALL SCREWS (4) AND TIGHTEN. <u>CROSSCHECK OF FUEL QUANTITY ON BOARD</u></p> <p>REF. FIG. 284281-CHK-00100 REF. FIG. 284281-CHK-00110</p> <p>CHECK COHERENCE OF FUEL QUANTITY INDICATED ON THE FQI AND THE PHYSICAL QUANTITY IN THE TANKS BY MEAN OF DRIPSTICKS. SEE JOB INSTRUCTION CARD:</p> <p style="text-align: right;">*** CONTINUED ***</p>			
EFFECTIVITY : R6		28-42-72 RAI 10000-003 2-400 PAGE 5 JUL 01/18		
Printed in France				
<div style="display: flex; align-items: center;"> <div> <p style="margin: 0;">ATR42-400/500 SERIES - AMM - Job Instruction Cards</p> </div> </div>				
TITLE		28-42-72 RAI 10000-003		
REMOVAL AND INSTALLATION OF FUEL QUANTITY OR FUEL TEMP/QUANTITY PROBE		STS.	CHECK	PAGE 6
				DATE JUL 18
ITEM	TASK DESCRIPTION	MECH.	INSP.	
008	<p>121128-CHK-10000 CONVERT VOLUME OBTAINED THROUGH DRIPSTICK IN WEIGHT BY MEAN OF CONVERSION TABLE OF FIGURES TAKING INTO ACCOUNT FUEL DENSITY OF THE DAY.</p> <p><u>CLOSE-UP</u></p> <p>1. DISCONNECT AIRCRAFT FROM TANKER. (IF IT HAS BEEN INSTALLED).</p>			

5.13 Troubleshooting manual section 28-21 revision 07/2017

Return to [preventative safety measures](#).



ATR42-400/500 SERIES - TROUBLE SHOOTING MANUAL

FAULT SYMPTOM	FAULT ISOLATION				
<ul style="list-style-type: none"> On panel 25VU, on FUEL/ENGL(2) caution light 7QA(8QA), FEED LO PR legend is illuminated. 	Fig. 101				
<ul style="list-style-type: none"> On CAP, FUEL legend is illuminated. No alarm reported on FUEL panel 25VU and no LO LVL amber caution light on FQI 3QT. 	Fig. 102				
<ul style="list-style-type: none"> On maintenance panel 702VU, the following configuration appears during the reading of the maintenance memory relative to the MISC2 system: <p style="margin-left: 40px;">BITE ADV DISPLAY SIGNIFICATION</p> <p style="margin-left: 40px;">8 4 2 1</p> <table border="1" style="margin-left: 40px; border-collapse: collapse;"> <tr> <td style="padding: 2px 5px;">F</td> <td style="padding: 2px 5px;">F</td> <td style="padding: 2px 5px;">F</td> <td style="padding: 2px 5px;">F</td> </tr> </table> <p style="margin-left: 40px;"><u>0 1 0 1</u> FUEL: ENGINE 1 FEEDER JET PUMP FAULT</p> <p style="margin-left: 40px;">OR</p> <p style="margin-left: 40px;"><u>0 1 1 0</u> FUEL: ENGINE 2 FEEDER JET PUMP FAULT</p>	F	F	F	F	Fig. 102
F	F	F	F		
<ul style="list-style-type: none"> On panel 25VU, on FUEL/ENGL(2) PUMP P/BSW 11QA(12QA), RUM legend remains illuminated after engine starting without additional warning. 	Fig. 103				

Engine Feed System

IL2821001A01002-03

EFFECTIVITY: ALL

R6

FAULT SYMPTOMS

28-21

Page 1
Jul 01/17

Printed in France

5.14 Operators revised OM-B procedure

Return to [preventative safety measures](#).

2.1.8.4 FUEL RECORDING PROCEDURE

- Before flight the remaining fuel must be recorded from FQI and crosschecked with previous fuel remaining record (NOTE 1 and NOTE 2);
- If refuelling is necessary, the uplifted fuel must be recorded and evaluated (NOTE 1 and NOTE 2);

Example 1:

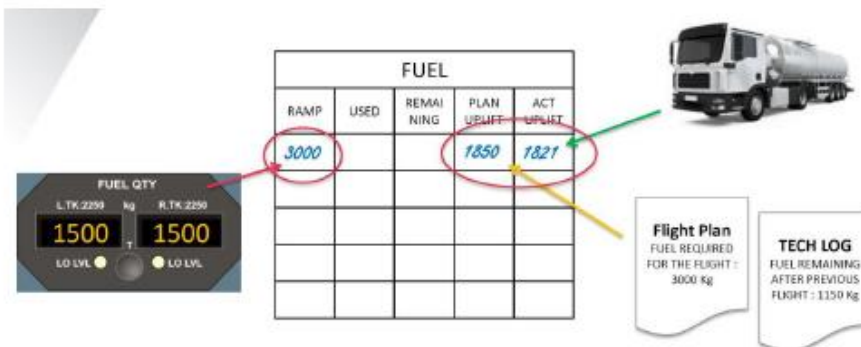

- During flight:
 - Actual consumption must be compared with planned consumption;
 - Remaining fuel must be checked enough to complete the flight; and
 - Expected fuel remaining upon arrival at destination must be determined.
- After flight, remaining fuel must be recorded from FQI, fuel used must be recorded from FU indicator and evaluated.

Example 2:

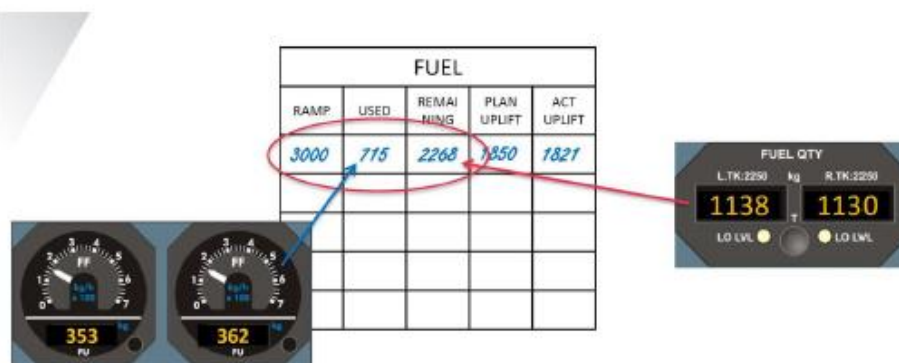

NOTE 1: If $\Delta > 3\%$ of fuel uplift, or $\Delta > 60$ kg per fuel tank, the crew should ask for a maintenance check of fuel actual quantity.

NOTE 2: FCOM provides figures of the accuracy of the FQI (PRO.NOP.NSU.28.3): $\Delta > 120$ kg for the total fuel uplift is in excess of the FQI accuracy, hence not acceptable.

Always compute / compare information from:

- Fuel quantity indicator (FQI)
- Fuel tanker receipt
- Fuel used (FU).